

Includes
Teacher's Notes
and
Typical
Experiment Results



***Instruction Manual and
Experiment Guide for
the PASCO scientific
Model TD-8551A***

012-04331E
5/94

MECHANICAL EQUIVALENT OF HEAT

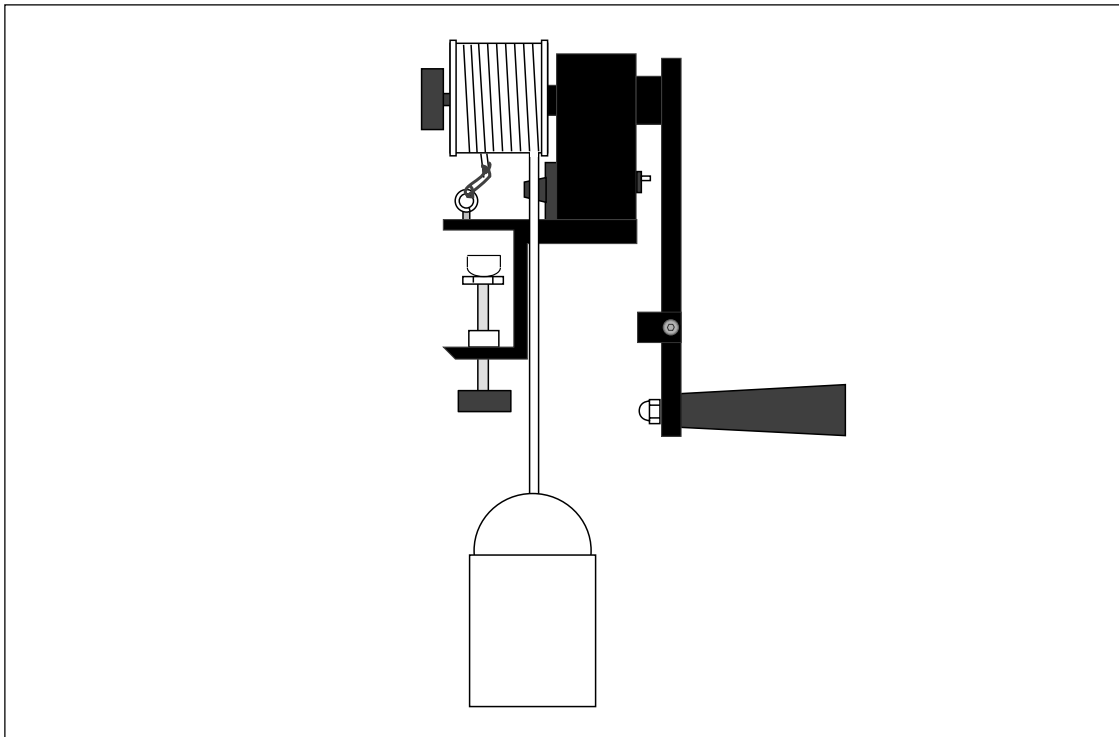

© 1990 PASCO scientific

\$5.00

PASCO®
scientific

10101 Foothills Blvd. • Roseville, CA 95747-7100
Phone (916) 786-3800 • FAX (916) 786-8905 • www.pasco.com

better
ways to
teach science

Table of Contents

Section	Page
Copyright and Warranty	ii
Equipment Return	ii
Introduction	1
Equipment	1
Measuring Temperature with the Thermistor	2
History	2
Operation	3
Measuring the Mechanical Equivalent of Heat:	
Experiment	4
Calculations	6
Worksheet	7
Maintenace	8
Thermistor Specifications:	
Temperature versus Resistance	9
Biography: Benjamin Thompson—Count Rumford of Bavaria.....	10
Teacher’s Guide	11

Copyright, Warranty and Equipment Return

Please—Feel free to duplicate this manual subject to the copyright restrictions below.

Copyright Notice

The PASCO scientific Model TD-8551A Mechanical Equivalent of Heat manual is copyrighted and all rights reserved. However, permission is granted to non-profit educational institutions for reproduction of any part of this manual providing the reproductions are used only for their laboratories and are not sold for profit. Reproduction under any other circumstances, without the written consent of PASCO scientific, is prohibited.

Limited Warranty

PASCO scientific warrants this product to be free from defects in materials and workmanship for a period of one year from the date of shipment to the customer. PASCO will repair or replace, at its option, any part of the product which is deemed to be defective in material or workmanship. This warranty does not cover damage to the product caused by abuse or improper use. Determination of whether a product failure is the result of a manufacturing defect or improper use by the customer shall be made solely by PASCO scientific. Responsibility for the return of equipment for warranty repair belongs to the customer. Equipment must be properly packed to prevent damage and shipped postage or freight prepaid. (Damage caused by improper packing of the equipment for return shipment will not be covered by the warranty.) Shipping costs for returning the equipment, after repair, will be paid by PASCO scientific.

Equipment Return

Should the product have to be returned to PASCO scientific for any reason, notify PASCO scientific by letter, phone, or fax BEFORE returning the product. Upon notification, the return authorization and shipping instructions will be promptly issued.

► **NOTE:** NO EQUIPMENT WILL BE ACCEPTED FOR RETURN WITHOUT AN AUTHORIZATION FROM PASCO.

When returning equipment for repair, the units must be packed properly. Carriers will not accept responsibility for damage caused by improper packing. To be certain the unit will not be damaged in shipment, observe the following rules:

- ① The packing carton must be strong enough for the item shipped.
- ② Make certain there are at least two inches of packing material between any point on the apparatus and the inside walls of the carton.
- ③ Make certain that the packing material cannot shift in the box or become compressed, allowing the instrument come in contact with the packing carton.

Address: PASCO scientific
10101 Foothills Blvd.
Roseville, CA 95747-7100

Phone: (916) 786-3800
FAX: (916) 786-3292
email: techsupp@pasco.com
web: www.pasco.com

Introduction

The principle of the conservation of energy tells us that if a given amount of work is transformed completely into heat, the resulting thermal energy must be equivalent to the amount of work that was performed. Of course, since work is normally measured in units of Joules and thermal energy is normally measured in units of Calories, the equivalence is not immediately obvious. A quantitative relationship is needed that equates Joules and Calories. This relationship is called the Mechanical Equivalent of Heat.

The PASCO scientific Model TD-8551A Mechanical Equivalent of Heat apparatus allows accurate determination of the Mechanical Equivalent of Heat (to within 5%). The apparatus is shown in Figure 1. A measurable amount of work is performed by turning the crank, which turns the aluminum cylinder. A nylon rope is wrapped several times around the cylinder so that, as the crank is turned, the friction between the rope and the cylinder is just enough to support a mass hanging from the other end of the rope. This insures that the torque acting on the cylinder is constant and measurable. A counter keeps track of the number of turns. As the cylinder turns, the friction between the cylinder and the rope converts the work into thermal energy, which raises the temperature of the aluminum cylinder. A thermistor is embedded in the aluminum so that, by measuring the

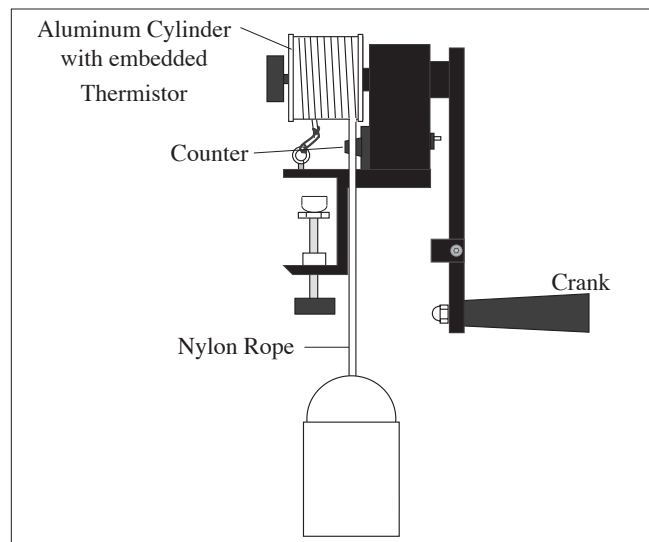

Figure 1 Mechanical Equivalent of Heat Apparatus

resistance of the thermistor, the temperature of the cylinder can be determined. By monitoring the temperature change of the cylinder, the thermal energy transferred into the cylinder can be calculated. Finally, the ratio between the work performed and the thermal energy transferred into the cylinder determines J , the mechanical equivalent of heat.

Equipment

The TD-8551A Mechanical Equivalent of Heat apparatus includes the items shown in Figure 2.

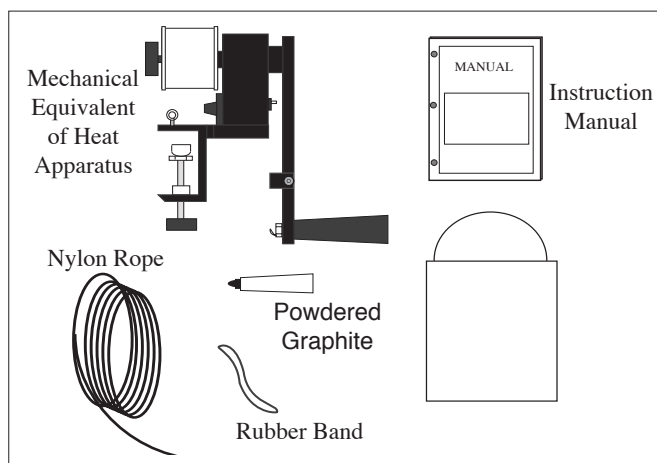

Figure 2 Equipment

► **IMPORTANT:** In addition to the Mechanical Equivalent of Heat apparatus, several other items are needed to measure the mechanical equivalent of heat. These items include:

- **Digital Ohmmeter** for measuring the resistance of the thermistor in the aluminum cylinder. (An analog meter can be used, but accuracy will be significantly sacrificed.)
- **Refrigerator** (or some **ice**), for cooling the aluminum cylinder below room temperature.
- **known Mass of approximately 10 kg** which can be suspended from the nylon rope. (The apparatus comes with a container which can be filled with sand or dirt for the 10 kg mass; if this is done, you will need an accurate balance for measuring this mass. Of course, you can fill the container by adding sand in measured increments of 1-2 kg.)
- **Thermometer** for measuring room temperature is convenient, though the thermistor can be used for this purpose.
- **Calipers** and a **Balance** for measuring the mass and diameter of the aluminum cylinder if you wish these measurements to be part of the experimental process. (Approximate values are Mass: 200 ± 1.5 grams; Diameter: 4.763 ± 0.02 cm; Diameter including thickness of nylon rope: 4.94 ± 0.05 cm. These values can be used, but there is some variation, so your results will be more accurate if you make the measurements yourself.)

Measuring Temperature with the Thermistor

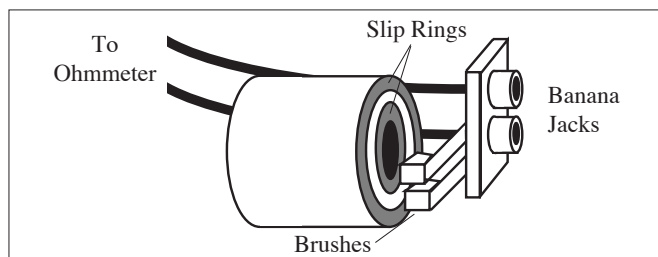

Figure 3 Measuring the Cylinder Temperature

To measure the temperature of the aluminum cylinder, a thermistor is embedded inside. A thermistor is a temperature dependent resistor. If the resistance of the thermistor is known, its temperature can be very accurately and reliably determined. The leads of the thermistor in the cylinder are

soldered to the copper slip rings (see Figure 3) on the side of the cylinder. The brushes provide an electrical connection between the slip rings and the banana plug connectors. By plugging an ohmmeter into these connectors, the resistance of the thermistor, and therefore its temperature, can be monitored, even when the cylinder is turning.

Although the temperature dependence of the thermistor is accurate and reliable, it is not linear. You will therefore need to use the table of Temperature versus Resistance that is affixed to the base of the Mechanical Equivalent of Heat apparatus to convert your resistance measurements into temperature readings. A more complete version of this table, covering a greater temperature range, is given at the end of this manual.

History

It may not seem strange to us today that there is a thing called energy that is conserved in all physical interactions. Energy is a concept we have all grown up with. A hundred and fifty years ago it was not so evident that there should be an intimate, quantitative relationship between such apparently unrelated phenomena as motion and heat. The discovery that heat and motion can be seen as different forms of the same thing—namely energy—was the first and biggest step toward understanding the concept of energy and its conservation.

Count Rumford of Bavaria, in 1798, was the first to realize that work and heat were related phenomena. At that time, it was commonly believed that heat resulted from the flow of a massless fluid-like substance called *caloric*. It was believed that this substance resided in objects, and that when they were cut, ground, or otherwise divided into smaller pieces, the pieces could not hold as much caloric as the original object. The resulting release of caloric was what we experience as heat.

While boring cannon for the Bavarian government, Rumford noticed that heat was produced even when the boring equipment had become so dulled from use that it was no longer boring into the iron. The heat therefore was not dependent on the breaking up of the metal into smaller pieces. In fact, this meant that a limitless amount of heat could be produced from the iron and boring equipment, an idea that was inconsistent with the belief that heat was the result of the release of a substance that resided in the material. Rumford realized that a connection existed between the motion of the bore and the heat. He even took

his reasoning a step further, stating his belief that only if heat were a form of motion would it demonstrate the properties he had observed.

It was not until the experiments of Joule in 1850, however, that Rumford's ideas about the nature of heat gained popular acceptance. Joule performed a variety of experiments in which he converted a carefully measured quantity of work, through friction, into an equally carefully measured quantity of heat. For example, in one experiment Joule used falling masses to propel a paddle wheel in a thermally insulated, water-filled container. Measurements of the distance through which the masses fell and the temperature change of the water allowed Joule to determine the work performed and the heat produced. With many such experiments, Joule demonstrated that the ratio between work performed and heat produced was constant. In modern units, Joule's results are stated by the expression:

$$1 \text{ calorie} = 4.186 \text{ Joule.}$$

Joule's results were within 1% of the value accepted today. (The calorie is now *defined* as equal to 4.184 Joule.)

It was this series of experiments that led Joule, along with several others, to the more general theory that energy is conserved in all physical processes.

► **NOTE:** See the short biography at the end of this manual for more information on the life of Benjamin Thompson—Count Rumford, of Bavaria.

Operation

Step by step instructions for using the Mechanical Equivalent of Heat Apparatus are given on the following pages. However, the apparatus will last longer and give better results if you follow the guidelines listed below:

- ① *Before performing the experiment, spray the surface of the aluminum cylinder lightly with the included dry powdered graphite.*

The graphite ensures that the rope slides smoothly on the cylinder, making it easier to provide a steady, even torque, and greatly decreasing the wear on the aluminum cylinder.

After several applications, the friction rope will become impregnated, so you needn't continue to apply the lubricant at every use.

- ② *Mount the Mechanical Equivalent of Heat on a level table.*

If the apparatus is not level the rope will tend to slip and bunch up on the cylinder, which makes it difficult to maintain a steady torque.

- ③ *When turning the crank, never raise the mass higher than about 3 cm from the floor (no higher than you would care to have it fall on your little toe).*

If the mass is raised higher, the crank can snap back when released, which is not healthy for the equipment, or for nearby people. Also, if it is allowed to climb, the rope will likely start overlapping the next turn which makes it climb even higher, producing a dangerous situation

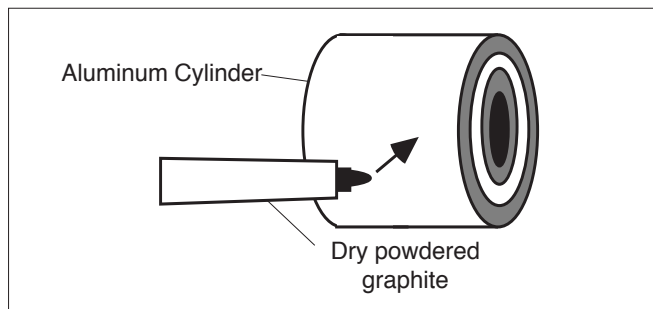

Figure 4 Lubricate Cylinder

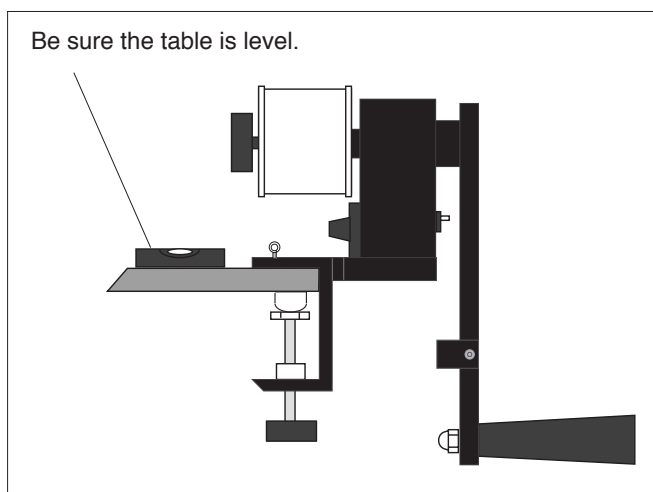

Figure 5 Level Table

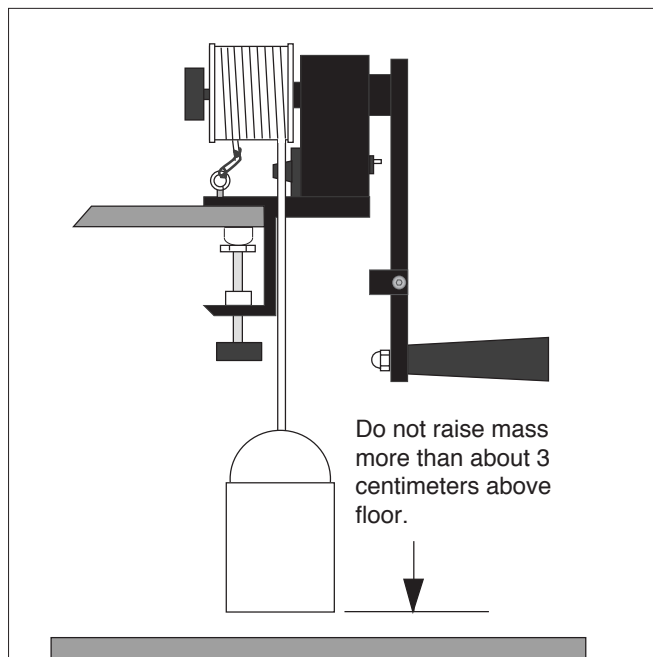

Figure 6 Don't Raise Mass too High

Experiment: Measuring the Mechanical Equivalent of Heat

► IMPORTANT:

- ① For best results, read this procedure through thoroughly before attempting the experiment
- ② A tube of powdered graphite lubricant is supplied with the equipment. Spraying the aluminum cylinder lightly with this before beginning the experiment will greatly reduce the wear on the aluminum surface.

► **NOTE:** An experimental worksheet is provided at the end of this section for recording data and calculations.

- ① Clamp the apparatus securely to the edge of a level table or bench, as shown in Figure 7.
- ② Unscrew the black knob and remove the aluminum cylinder. Place the cylinder in a refrigerator or freezer, or pack it in ice, to bring the temperature down to at least 10 C° below room temperature.

The cylinder is cooled so that, when it is heated by friction, the midpoint of the high and low temperatures will be at room temperature. In the first half of the experiment, therefore, heat will be transferred from the room air into the cooler cylinder. As the cylinder heats beyond room temperature though, heat will be transferred out of the cylinder back into the room atmosphere. By letting the change in cylinder temperature be symmetrical about the room temperature, the quantity of heat transferred to and from the cylinder and room should be approximately equal.

- ③ While the cylinder is cooling, plan the desired temperature variation of the experiment. Ideally, the temperature variation of the cylinder should be from 7-9 C° below room temperature to the same amount above room temperature. Therefore, measure and record the room temperature, and then determine and record the initial and final temperatures you wish the cylinder to reach during the experiment. (You can record your data on the data sheet provided at the end of this section.)
- ④ Using the table of Resistance versus Temperature for the thermistor, determine the resistance value which will correspond to each of your recorded temperatures. (A table covering most temperature ranges is listed on the apparatus. A more complete table can be found near the end of this manual.) Also determine the resistance measurement which corresponds to 1 C° below the final temperature. You will want to start cranking more slowly as the temperature approaches this point, so that the final, equilibrium temperature will be close to your chosen final temperature.
- ⑤ When the cylinder is sufficiently cool, slide it back on the crank shaft. Be sure that the copper plated board is facing toward the crank. Also make sure that the pins on the drive shaft fit into the slots on the plastic ring on the cylinder, then replace the black knob and tighten securely.
- ⑥ Plug the leads of the ohmmeter into the banana plug connectors as shown in Figure 8. Set the ohmmeter to a range that is appropriate to the thermistor resistances that correspond to your chosen temperature range.
- ⑦ Wrap the nylon rope several turns around the aluminum cylinder (4-6 turns should work well) as shown in Figure 9. Be sure that the rope lies flat against the cylinder and hangs down the slot provided in the base plate. Tie one end of the rope, the end nearest to the crank, to the 10 kg mass as shown.

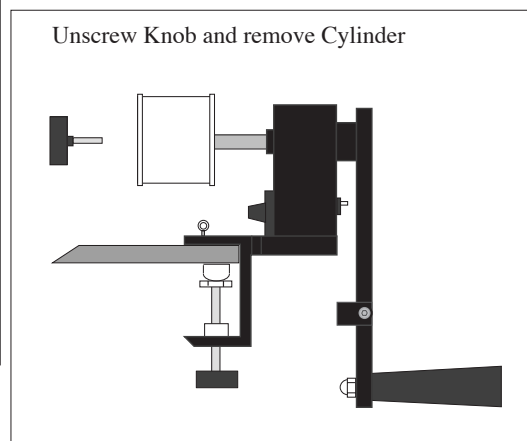

Figure 7 Clamp to Table and Remove Cylinder

► **NOTE:** When the cylinder is cold, water may condense on its surface. Dry the cylinder thoroughly with a cloth or paper towel before wrapping the rope, so that all of the heat goes into heating the cylinder and not into evaporating the condensed water.

- ⑧ Set the counter to zero by turning the black knob on the counter.
- ⑨ Watch the ohmmeter carefully. When the resistance reaches the value corresponding to your starting temperature, start cranking (clock-wise, facing the crank side of the apparatus).

► **IMPORTANT:** There should be only enough turns of rope around the cylinder so that the frictional pull on the rope is just enough to lift the hanging mass **about 3 cm off the floor - no higher!** To accomplish this, wrap the rope three or four turns and crank. Add turns as needed to support the mass while cranking with only very slight tension on the free end. Attach the rubber band to the free end of the rope. Now, without cranking and while keeping the rope taut by the rubber band, tie the other end of the rubber band to the eyebolt on the baseplate. If you find that the large hanging mass continues to rise more than 3 cm as you turn the crank, remove one turn from the cylinder nearest the free end. If the large hanging mass continues to rest on the floor, add another turn of rope around the cylinder at the free end.

Crank rapidly until the temperature indicated by the thermistor is 1°C less than your designated stopping temperature, then crank very slowly while watching the ohmmeter. When the temperature reaches your stopping value, stop cranking. Continue watching the ohmmeter until the thermistor temperature reaches a maximum (the resistance will be a minimum) and starts to drop. Record the highest temperature attained as your final temperature.

- ⑩ Record N , the number on the counter—the number of full turns of the crank.
- ⑪ Measure and record m , the mass of the aluminum cylinder.
- ⑫ With a pair of calipers, measure D , the diameter of the aluminum cylinder. Record the radius of the cylinder in the worksheet ($R = \frac{D}{2}$).

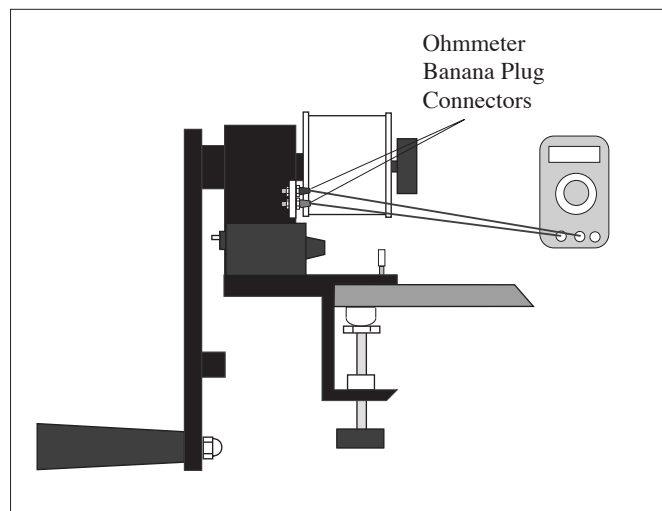

Figure 8 Hook up the Ohmmeter

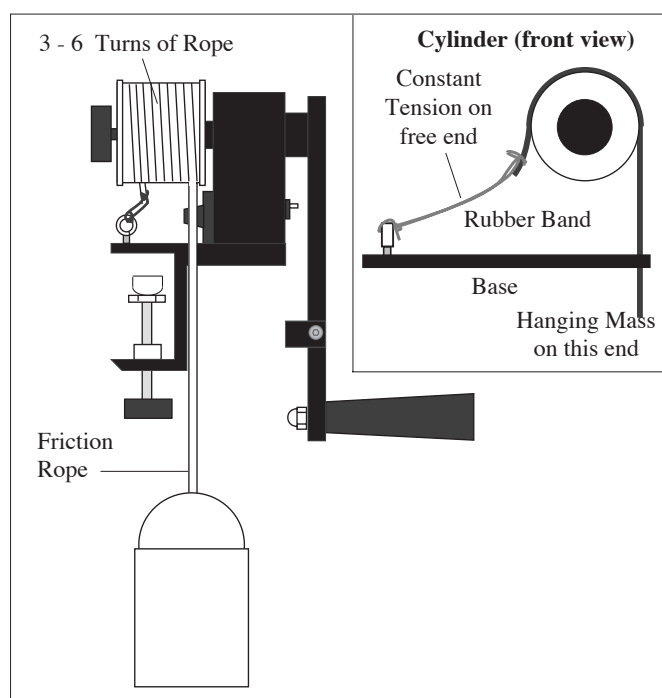

Figure 9 Add Friction Rope and Hanging Mass

Calculations

Calculating W , the Work Performed

The work performed on the cylinder by turning the crank equals τ , the torque acting on the cylinder, times θ , the total angle through which the torque acts. It would be difficult to directly measure the torque delivered by the crank. However, since the motion of the cylinder is more or less constant through the experiment, we know that the torque provided by the crank must just balance the torque provided by the friction from the rope. The torque provided by the rope friction is easily calculated. It is just:

$$\tau = MgR$$

where M is the mass hanging from the rope, g is the acceleration due to gravity, and R is the radius of the cylinder.

Each time the crank is turned one full turn, this torque is applied to the cylinder through an angle 2π . The total work performed therefore is:

$$W = \tau\theta = MgR (2\pi N);$$

where M is the mass hanging from the rope;
 g is the acceleration due to gravity (9.8 m/s^2);
 R is the radius of the aluminum cylinder;
 and N is the total number of times the crank was turned.

Calculating Q , the Heat produced

The heat (Q) produced by friction against the aluminum cylinder can be determined from the measured temperature change that occurred. The calculation is:

$$Q = m c (T_f - T_i);$$

where m is the mass of the aluminum cylinder;
 c is the specific heat of aluminum ($0.220 \text{ cal/gC}^\circ$);
 T_f is the final temperature of the cylinder;
 and T_i is the initial temperature of the cylinder, just before cranking.

Calculating J , the Mechanical Equivalent of Heat

J is just the ratio of the work performed to the heat produced. Therefore:

$$J = W/Q$$

Worksheet

Data

	Temperature ($^{\circ}\text{C}$)	Corresponding Thermistor Resistance (Ω)
Room Temperature		
Initial Temperature (T_i)		
Final Temperature (T_f)		
Ideal (pre-selected value)		
Actual (Highest Temp)		
$T_f - 1^{\circ}\text{C}$ (Begin Slow Cranking)		

Mass Hanging from Rope: $M =$ _____

Mass of Aluminum Cylinder: $m =$ _____

Radius of Cylinder: $R =$ _____

Number of turns of crank : $N =$ _____

Calculations

Work performed on cylinder: $W = \tau \theta = MgR(2\pi N) =$ _____

Heat absorbed by cylinder: $Q = mc (T_f - T_i) =$ _____

Mechanical Equivalent of Heat: $J = W/Q =$ _____

(Acceleration due to gravity: $g = 9.8 \text{ m/s}^2$; Specific Heat of Aluminum: $c = 0.220 \text{ cal/g}^{\circ}\text{C}$)

Suggested Questions

- ① Compare your value of **J** with the accepted value (check your textbook).
- ② Discuss any sources of error that you feel might have affected your results. Are some of these avoidable? What affect would they have on your calculated value for **J**? Can you estimate the magnitude of the effects?
- ③ Is it experimentally possible that the heat absorbed by the cylinder could be greater than the work performed on it? Explain.
- ④ Can your value of **J** be used for determining how much mechanical energy can be produced from a specified amount of thermal energy? Why or why not?

Maintenance

The Mechanical Equivalent of Heat apparatus requires no regular maintenance except to lubricate the aluminum cylinder periodically to ensure that the friction rope slides freely.

If the slip-ring or brushes become dirty enough so they do not conduct well and affect the thermistor resistance, just clean them with alcohol (if you have no alcohol handy, a damp rag will probably do the trick).

Assorted Replacement Parts List

Part No.	Description
648-04336	Friction Cylinder
555-04303	Commutator PCB
150-027	Thermistor 100K +/- 2°C
620-039	Cylinder Handscrew
003-02861	Brush Assembly
621-020	Crank Handle
699-050	Mechanical Counter
003-04382	Cord Assembly

Thermistor Specifications:

Temperature Versus Resistance

Res. (Ω)	Temp. ($^{\circ}\text{C}$)	Res. (Ω)	Temp. ($^{\circ}\text{C}$)	Res. (Ω)	Temp. ($^{\circ}\text{C}$)
351,020	0	66,356	34	16,689	68
332,640	1	63,480	35	16,083	69
315,320	2	60,743	36	15,502	70
298,990	3	58,138	37	14,945	71
283,600	4	55,658	38	14,410	72
269,080	5	53,297	39	13,897	73
255,380	6	51,048	40	13,405	74
242,460	7	48,905	41	12,932	75
230,260	8	46,863	42	12,479	76
218,730	9	44,917	43	12,043	77
207,850	10	43,062	44	11,625	78
197,560	11	41,292	45	11,223	79
187,840	12	39,605	46	10,837	80
178,650	13	37,995	47	10,467	81
169,950	14	36,458	48	10,110	82
161,730	15	34,991	49	9,767.2	83
153,950	16	33,591	50	9,437.7	84
146,580	17	32,253	51	9,120.8	85
139,610	18	30,976	52	8,816.0	86
133,000	19	29,756	53	8,522.7	87
126,740	20	28,590	54	8,240.6	88
120,810	21	27,475	55	7,969.1	89
115,190	22	26,409	56	7,707.7	90
109,850	23	25,390	57	7,456.2	91
104,800	24	24,415	58	7,214.0	92
100,000	25	23,483	59	6,980.6	93
95,447	26	22,590	60	6,755.9	94
91,126	27	21,736	61	6,539.4	95
87,022	28	20,919	62	6,330.8	96
83,124	29	20,136	63	6,129.8	97
79,422	30	19,386	64	5,936.1	98
75,903	31	18,668	65	5,749.3	99
72,560	32	17,980	66	5,569.3	100
69,380	33	17,321	67		

The Incredible Career of Count Rumford

One of the most incredible men associated with science was Benjamin Thompson, later titled Count Rumford. Aside from making as many enemies as friends, this man amassed a large list of honorary titles and contributed significantly to scientific knowledge. He never let an opportunity for advancement escape him and many claimed he had "no real love or regard for his fellow men." Nevertheless he was one of the first American scientists and his career was probably the strangest of all American success stories.

Thompson was born into a Massachusetts farming family in 1763. He was a strange boy who fancied he could build a perpetual motion machine and took great interest in eclipses. He became an itinerant teacher and was hired by a wealthy family in Rumford, Massachusetts. After endearing himself to nearly everyone, Benjamin married the daughter of the household and was accepted into high society. So favorably did he impress the local military officers that he was made a major at age 19. This undeserved honor made him quite unpopular with the local citizenry. In fact as the political climate ripened for revolution, Thompson was arrested "upon suspicion of being inimical to the liberties of this Country." Perhaps he was a spy, but most likely he was indifferent to the revolutionary cause. When released he left his wife and fled to England.

His charming manner and good looks won the friendship of the War Minister and soon he was elected to the Royal Society and named Under Secretary in the War Department. He returned to America to command the Queen's Horse Dragoons against the colonists. During this time he strangely enough began systematic lunar observations and extensive experiments with gunpowder and shell velocity.

At age 30 he returned to England and traveled to Bavaria. He won the friendship of the duke of Bavaria and in due time was made a Count of the Holy Roman Empire—Count Rumford. Thompson was bright enough and had enough power to apply his cherished ideas of enlightened despotism; he established a successful welfare system in Munich.

This was the time he made his greatest contribution to science. While watching a cannon being bored he noted the extreme amount of heat produced. After careful experiments he was able to deduce that heat was molecular motion, not a fluid. This was a breakthrough.



Benjamin Thompson
1763-1814

Count Rumford was a careful observer. He installed a glass door in his fireplace, watched the flame carefully, and soon designed better stoves and better chimneys. He built up quite a reputation as a nutritionist; he wrote several essays on the benefits of coffee over tea. Many credit him with inventing the folding bed and he made many improvements in the design of lamps. His main scientific accomplishment in later life was his large role in founding the Royal Institution in 1800. It was Count Rumford who hired Humphrey Davy as lecturer at the Institution and it was Count Rumford's money that kept the Institution going in the beginning. Soon, however, the Institution became too theoretical for Thompson and he severed connection with it to move to France. He died in 1814 of a fever. He left his gold watch to Sir Humphrey Davy and much of his money to Harvard University.

Although much of what Benjamin Thompson did in his lifetime was simply not cricket, he was an "enlightened philanthropist" and did more for society and science than most men.

Reference: *Count Rumford of Massachusetts*
Thompson, James Alden
Farrar & Rinehart, New York 1935

Written by Steven Janke

Teacher's Guide

Experiment: Measuring the Mechanical Equivalent of Heat

Procedure

- ② It is often helpful to bring the cylinder down to several degrees below the desired starting temperature. This allows you time to determine the number of turns of rope needed before actually taking data.
- ⑨ It is best to crank the cylinder as rapidly as possible. This minimizes the time in which heat can escape to the environment

Questions

- ① The accepted value of J is 4.184 Joules/calorie. It is reasonable to expect results within 2% of this value. (Typical results are $J = 4.144$ Joules/calorie)
- ② Some sources of error might be loss of heat to the environment, inaccurate measurement of temperature, the fact that not all of the drum is aluminum (and thus parts of it have a different specific heat), and nonuniform temperature in the drum. If the experiment is done carefully, these are negligible.
- ③ No. If the heat absorbed by the cylinder was more than the work done on it, PASCO scientific would be selling perpetual motion machines instead of real physics apparatus. It is possible that students may measure the heat as being more than the work done, but this is experimental error.
- ④ Not directly. There are many other factors that will come into the calculations, including Carnot efficiency.

Notes

Technical Support

Feed-Back

If you have any comments about this product or this manual please let us know. If you have any suggestions on alternate experiments or find a problem in the manual please tell us. PASCO appreciates any customer feedback. Your input helps us evaluate and improve our product.

To Reach PASCO

For Technical Support call us at 1-800-772-8700 (toll-free within the U.S.) or (916) 786-3800.

Contacting Technical Support

Before you call the PASCO Technical Support staff it would be helpful to prepare the following information:

- If your problem is with the PASCO apparatus, note:
Title and Model number (usually listed on the label).
Approximate age of apparatus.

A detailed description of the problem/sequence of events. (In case you can't call PASCO right away, you won't lose valuable data.)

If possible, have the apparatus within reach when calling. This makes descriptions of individual parts much easier.

- If your problem relates to the instruction manual, note:
Part number and Revision (listed by month and year on the front cover).

Have the manual at hand to discuss your questions.

