

Includes
Teacher's Notes
and
Typical
Experiment Results



**Instruction Manual and
Experiment Guide for
the PASCO scientific
Model WA-9314B**

012-04630F
4/99

MICROWAVE OPTICS

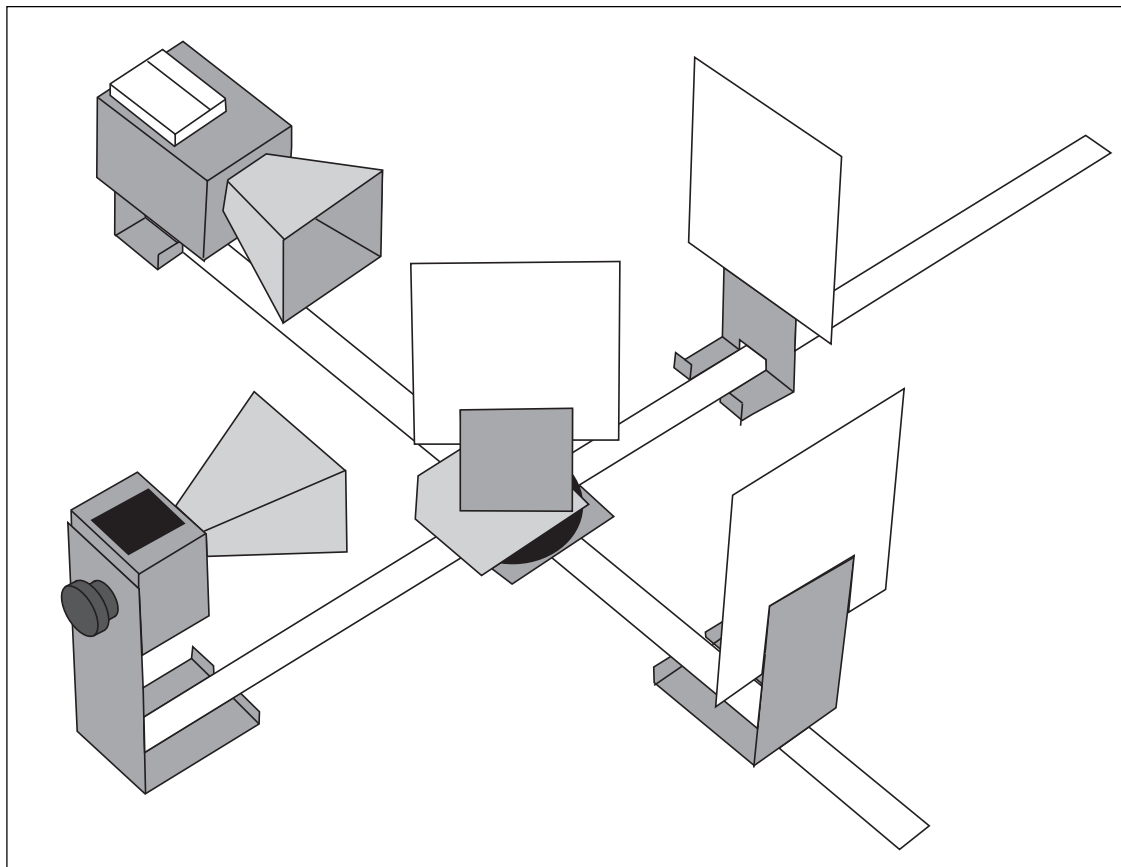

© 1991 PASCO scientific

\$10.00

PASCO[®]
scientific

10101 Foothills Blvd. • Roseville, CA 95747-7100
Phone (916) 786-3800 • FAX (916) 786-8905 • www.pasco.com

better
ways to
teach science

Table of Contents

Section	Page
Copyright, Warranty, and Equipment Return	ii
Introduction	1
Equipment	1
Initial Setup	3
Accessory Equipment	3
Assembling Equipment for Experiments	5
Experiments	
Experiment 1: Introduction to the System	7
Experiment 2: Reflection	11
Experiment 3: Standing Waves - Measuring Wavelengths	13
Experiment 4: Refraction Through a Prism	17
Experiment 5: Polarization	19
Experiment 6: Double-Slit Interference	21
Experiment 7: Lloyds Mirror	23
Experiment 8: Fabry-Perot Interferometer	25
Experiment 9: Michelson Interferometer	27
Experiment 10: Fiber Optics	29
Experiment 11: Brewster's Angle	31
Experiment 12: Bragg Diffraction	33
Teacher's Guide	35
Appendix	45
Schematic Diagrams	46
Replacement Parts List	47

Copyright, Warranty, and Equipment Return

Please—Feel free to duplicate this manual subject to the copyright restrictions below.

Copyright Notice

The PASCO scientific 012-04630E Model WA-9314B Microwave Optics manual is copyrighted and all rights reserved. However, permission is granted to non-profit educational institutions for reproduction of any part of the manual providing the reproductions are used only for their laboratories and are not sold for profit. Reproduction under any other circumstances, without the written consent of PASCO scientific, is prohibited.

Limited Warranty

PASCO scientific warrants the product to be free from defects in materials and workmanship for a period of one year from the date of shipment to the customer. PASCO will repair or replace at its option any part of the product which is deemed to be defective in material or workmanship. The warranty does not cover damage to the product caused by abuse or improper use. Determination of whether a product failure is the result of a manufacturing defect or improper use by the customer shall be made solely by PASCO scientific. Responsibility for the return of equipment for warranty repair belongs to the customer. Equipment must be properly packed to prevent damage and shipped postage or freight prepaid. (Damage caused by improper packing of the equipment for return shipment will not be covered by the warranty.) Shipping costs for returning the equipment after repair will be paid by PASCO scientific.

Credits

This manual edited by: Dave Griffith

Teacher's guide written by: Eric Ayars

Equipment Return

Should the product have to be returned to PASCO scientific for any reason, notify PASCO scientific by letter, phone, or fax BEFORE returning the product. Upon notification, the return authorization and shipping instructions will be promptly issued.

► **NOTE:** NO EQUIPMENT WILL BE ACCEPTED FOR RETURN WITHOUT AN AUTHORIZATION FROM PASCO.

When returning equipment for repair, the units must be packed properly. Carriers will not accept responsibility for damage caused by improper packing. To be certain the unit will not be damaged in shipment, observe the following rules:

- ① The packing carton must be strong enough for the item shipped.
- ② Make certain there are at least two inches of packing material between any point on the apparatus and the inside walls of the carton.
- ③ Make certain that the packing material cannot shift in the box or become compressed, allowing the instrument come in contact with the packing carton.

Address: PASCO scientific
10101 Foothills Blvd.
Roseville, CA 95747-7100

Phone: (916) 786-3800
FAX: (916) 786-3292
email: techsupp@pasco.com
web: www.pasco.com

Introduction

There are many advantages to studying optical phenomena at microwave frequencies. Using a 2.85 centimeter microwave wavelength transforms the scale of the experiment. Microns become centimeters and variables obscured by the small scale of traditional optics experiments are easily seen and manipulated. The PASCO scientific Model WA-9314B Basic Microwave Optics System is designed to take full advantage of these educational benefits. The Basic Microwave Optics System comes with a 2.85 centimeter wavelength microwave transmitter and a receiver with variable amplification (from 1X to 30X). All the accessory equipment needed to investigate a variety of wave phenomena is also included.

This manual describes the operation and maintenance of the microwave equipment and also gives detailed instructions for many experiments. These experiments range from quantitative investigations of reflection and refraction to microwave models of the Michelson and Fabry-Perot interferometers. For those who have either the Complete Microwave Optics System (WA-9316) or the Microwave Accessory Package (WA-9315), the manual describes experiments for investigating Bragg diffraction and Brewster's angle.

Equipment

Gunn Diode Transmitter

The Gunn Diode Microwave Transmitter provides 15 mW of coherent, linearly polarized microwave output at a wavelength of 2.85 cm. The unit consists of a Gunn diode in a 10.525 GHz resonant cavity, a microwave horn to direct the output, and an 18 cm stand to help reduce table top reflections. The Transmitter may be powered directly from a standard 115 or 220/240 VAC, 50/60 Hz outlet by using the provided power supply. Other features include an LED power-indicator light and a rotational scale that allows easy measurement of the angle of polarization.

The Gunn diode acts as a non-linear resistor that oscillates in the microwave band. The output is linearly polarized along the axis of the diode and the attached horn radiates a strong beam of microwave radiation centered along the axis of the horn.

To Operate the Microwave Transmitter

Simply plug the power supply into the jack on the Transmitter's bottom panel and plug the power supply into a standard 115 or 220/240 VAC, 50/60 Hz outlet. The LED will light indicating the unit is on.

► **CAUTION:** *The output power of the Microwave Transmitter is well within standard safety levels. Nevertheless, one should never look directly into the microwave horn at close range when the Transmitter is on.*

Power Supply Specifications:

9 Volt DC, 500 mA;

Miniature Phone Jack Connector (the tip is positive)

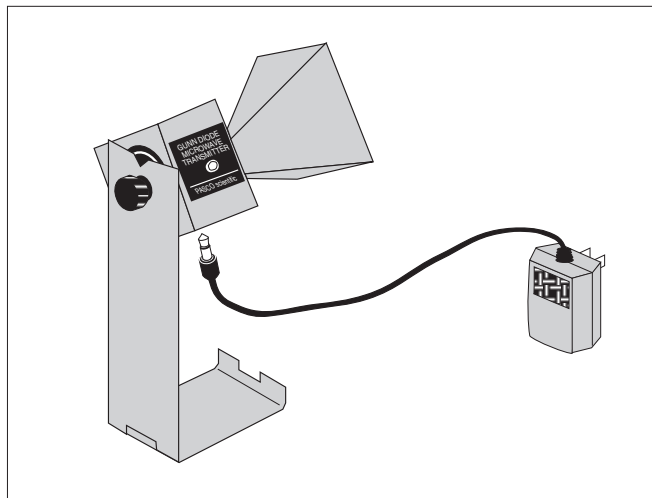

Microwave Transmitter with Power Supply

Microwave Receiver

The Microwave Receiver provides a meter reading that, for low amplitude signals, is approximately proportional to the intensity of the incident microwave signal. A microwave horn identical to that of the Transmitter's collects the microwave signal and channels it to a Schottky diode in a 10.525 GHz resonant cavity. The diode responds only to the component of a microwave signal that is polarized along the diode axis, producing a DC voltage that varies with the magnitude of the microwave signal.

Special features of the Receiver include four amplification ranges—from one to thirty—with a variable sensitivity knob that allows fine tuning of the amplification in each range. For convenience in class demonstrations, banana plug connectors provide for an output signal via hookup to a projection meter (such as PASCO Model ES-9065 Projection Meter or SE-9617 DC Voltmeter). This output can also be used for close examination of the signal using an oscilloscope. The receiver is battery powered and has an LED battery indicator; if the LED lights when you turn on the Receiver, the battery is working. As with the Transmitter, an 18 cm high mount minimizes table top reflections, and a rotational scale allows convenient measurements of polarization angle.

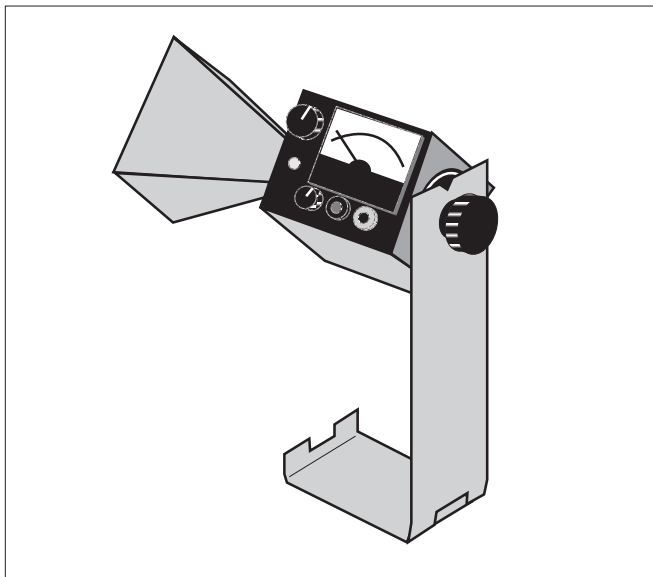

Microwave Receiver

The female audio connector on the side of the Receiver is for an optional Microwave Detector Probe (PASCO Model WA-9319). The probe works the same as the Receiver except it has no horn or resonant cavity. The Probe is particularly convenient for examining wave patterns in which the horn could get in the way, such as the standing wave pattern described in Experiment 3 of this manual.

►**NOTE:** *The detector diodes in the Receiver (and the Probe) are non-linear devices. This non-linearity will provide no problem in most experiments. It is important however, to realize that the meter reading is not directly proportional to either the electric field (E) or the intensity (I) of the incident microwave. Instead, it generally reflects some intermediate value.*

To Operate The Microwave Receiver:

►**NOTE:** *Before using the Receiver, you will need to install the two 9-volt transistor batteries—they are included with the system. See the instructions in the Maintenance section at the end of this manual.*

- ① Turn the INTENSITY selection switch from OFF to 30X, the lowest amplification level. The battery indicator LED should light, indicating that the battery is okay. If it does not, replace the battery following the procedures in the Maintenance section of this manual.

►**NOTE:** *The INTENSITY selection settings (30X, 10X, 3X, 1X) are the values you must multiply the meter reading by to normalize your measurements. 30X, for example, means that you must multiply the meter reading by 30 to get the same value you would measure for the same signal with the INTENSITY selection set to 1X. Of course, this is true only if you do not change the position of the VARIABLE SENSITIVITY knob between measurements.*

- ② Point the microwave horn toward the incident microwave signal. Unless polarization effects are under investigation, adjust the polarization angles of the Transmitter and Receiver to the same orientation (e.g., both horns vertically, or both horns horizontally).
- ③ Adjust the VARIABLE SENSITIVITY knob to attain a meter reading near midscale. If no deflection of the meter occurs, increase the amplification by turning the INTENSITY selection switch clockwise. Remember, always multiply your meter reading by the appropriate INTENSITY selection (30X, 10X, 3X, or 1X) if you want to make a quantitative comparison of measurements taken at different INTENSITY settings.

Initial Setup

To attach the microwave Transmitter and Receiver to their respective stands prior to performing experiments, proceed as follows:

- ① Remove the black hand screw from the back panel of both the Transmitter and the Receiver.
- ② Attach both units to the stands as shown below. Observe the location of the washers.
- ③ **To adjust the polarization angle of the Transmitter or Receiver**, loosen the hand screw, rotate the unit, and tighten the hand screw at the desired orientation. Notice the rotational scale on the back of each unit for measuring the angle of polarization. Be aware, however, that since the Transmitter and Receiver face each other in most experiments it is important to match their polarization angle. If you rotate one unit to an angle of 10-degrees, you must rotate the other to -10-degrees (350-degrees) to achieve the proper polar alignment.

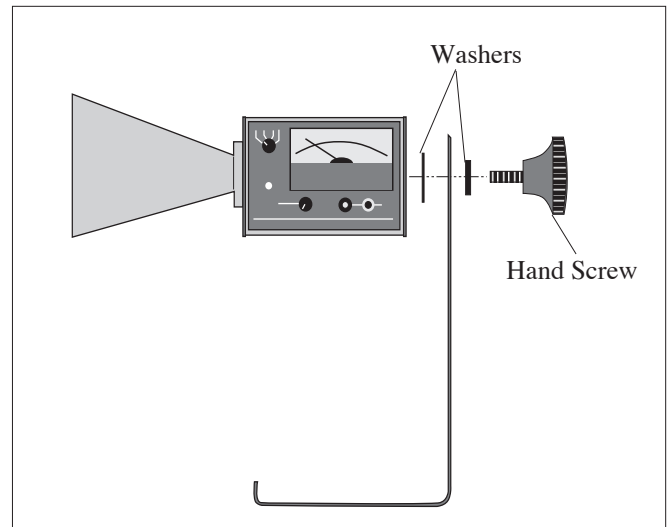

Attaching the Transmitter and Receiver Stands

Accessory Equipment

Accessory equipment for the Basic Microwave Optics System includes:

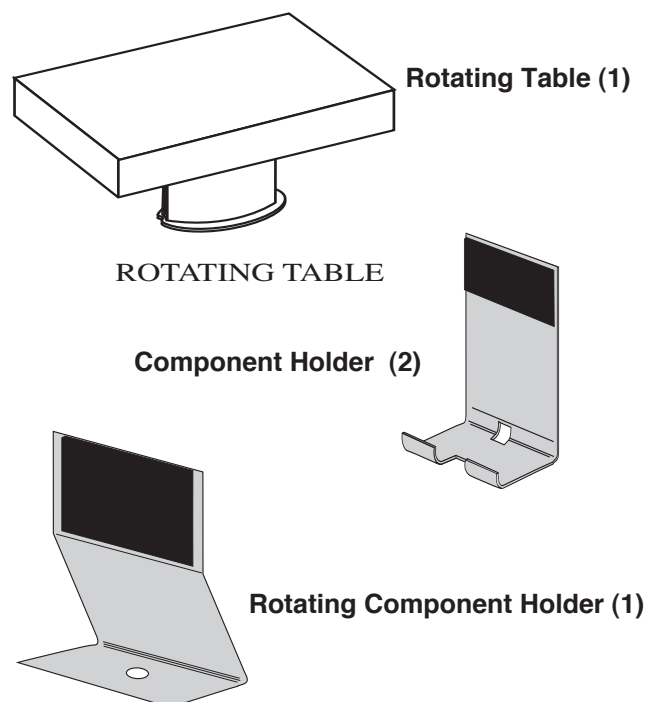
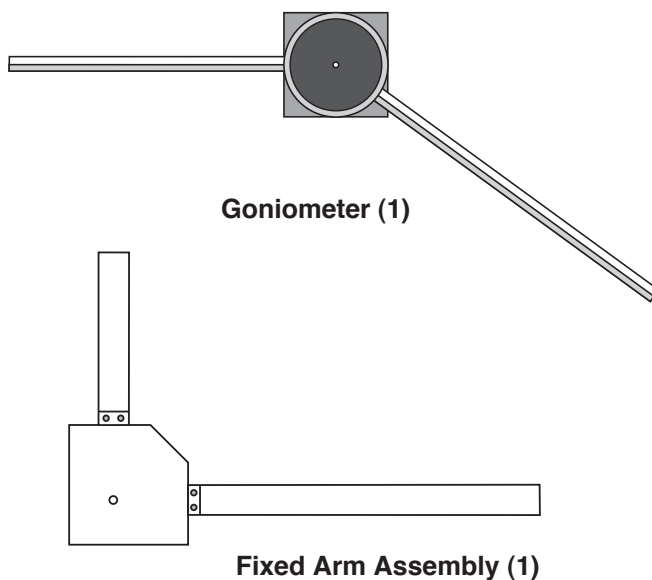



Metal Reflector (2)



Partial Reflector (2)

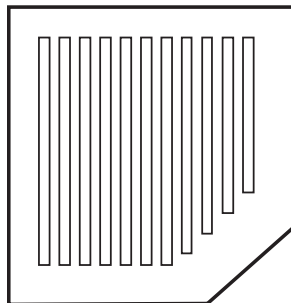

Polarizers (2)

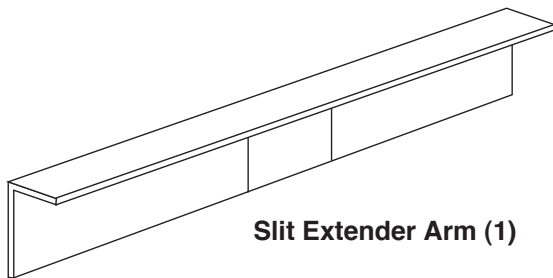

Slit Extender Arm (1)



Narrow Slit Spacer (1)

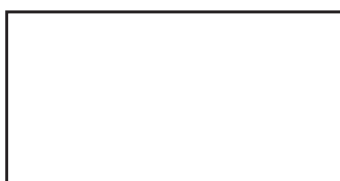

Wide Slit Spacer (1)

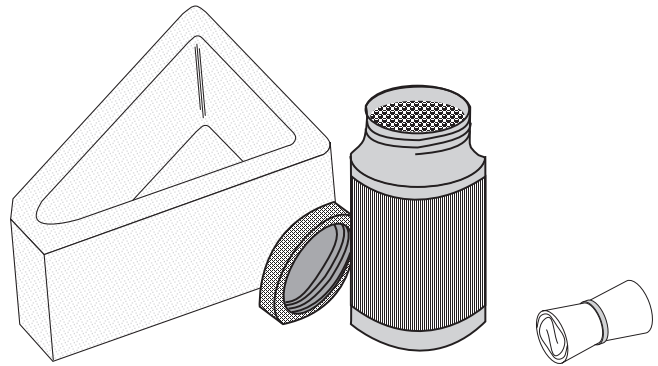

**Ethafoam Prism Mold w/
Styrene Pellets (1)**

**Tubular
Plastic Bags (4)**

The WA-9315 Microwave Accessory Package (which is part of the Complete Microwave Optics System Model WA-9316) includes the following:

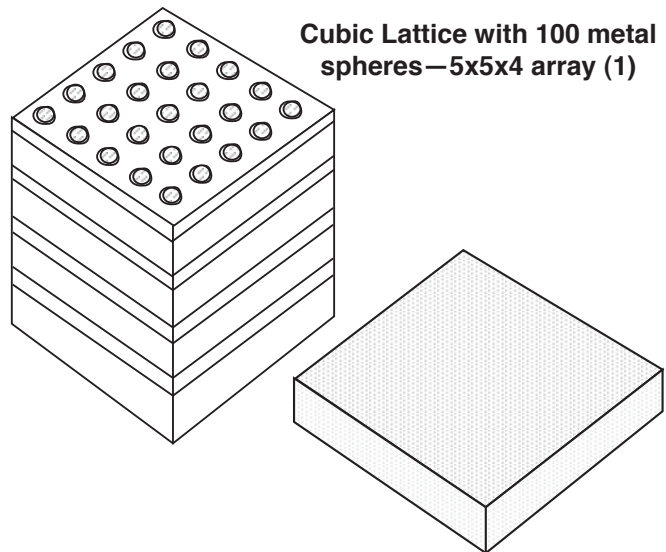

**Cubic Lattice with 100 metal
spheres—5x5x4 array (1)**

Polyethylene Panel (1)

The following components, compatible with the WA-9314B Basic Microwave Optics System, are available from PASCO scientific:

Model WA-9319 Microwave Detector Probe plugs directly into the Microwave Receiver. The probe is essential for experiments in which the horn of the Receiver might otherwise interfere with the wave pattern being measured.

Model WA-9318 Microwave Modulation Kit includes a modulator and microphone. With this kit, you can use your Transmitter and Receiver as a microwave communications system.

Assembling Equipment for Experiments

The arms of the Goniometer slide through the holes in the Component Holders as shown. Make sure the magnetic strip on the bottom of the arm grips the base of the carriage. To adjust the position of the holders, just slide them along the Goniometer arms. Attach the mounting stands of the microwave Transmitter and Receiver to the arms of the Goniometer in the same manner.

For most experiments it is advantageous to attach the Transmitter to the long arm of the Goniometer and the Receiver to the shorter, rotatable arm. This maintains a fixed relationship between the microwave beam and components mounted on the long arm (or on the degree plate) of the Goniometer. In turn the Receiver moves easily to sample the output.

Reflectors, Partial Reflectors, Polarizers, Slit Spacers, and the Slit Extender Arm all attach magnetically to the Component Holders. The metric scale along the Goniometer arms and the degree plate at the junction of the arms allow easy measurement of component placement. When rotating the rotatable arm, hold the degree plate firmly to the table so that it does not move.

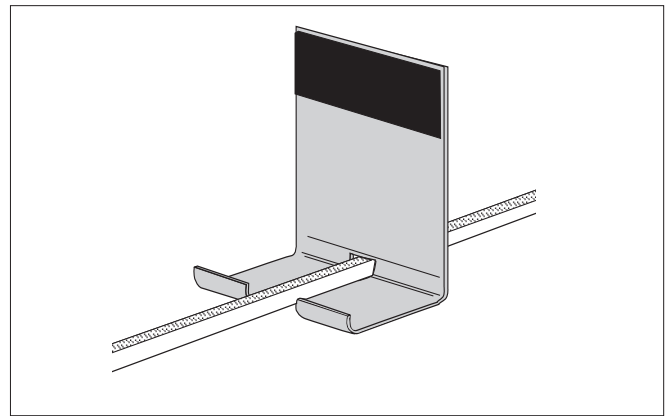

Mounting the Component Holder

► IMPORTANT NOTES:

1. **CAUTION**—Under some circumstances, microwaves can interfere with electronic medical devices. *If you use a pacemaker, or other electronic medical device*, check with your doctor or the manufacturer to be certain that low power microwaves at a frequency of 10.525 GHz will not interfere with its operation.
2. Always mount the apparatus on a CLEAN, SMOOTH table. Before setting up the equipment, brush off any material—*particularly metal chips*—that might have adhered to the magnetic strips on the bottom of the Goniometer arms.

Copy-Ready Experiments

The following Experiments provide a thorough introduction to wave theory using the microwave system. We expect that the student approaches each experiment with the appropriate theoretical background, therefore, basic principles are only briefly discussed in each experiment.

The experiments are written in worksheet format. Feel free to photocopy them for use in your lab.

Experiment 1: Introduction to the System

EQUIPMENT NEEDED:

- Transmitter
- Receiver
- Goniometer
- Reflector (1)

Purpose

This experiment gives a systematic introduction to the Microwave Optics System. This may prove helpful in learning to use the equipment effectively and in understanding the significance of measurements made with this equipment. It is however not a prerequisite to the following experiments.

Procedure

- ① Arrange the Transmitter and Receiver on the Goniometer as shown in Figure 1.1 with the Transmitter attached to the fixed arm. Be sure to adjust both Transmitter and Receiver to the same polarity—the horns should have the same orientation, as shown.

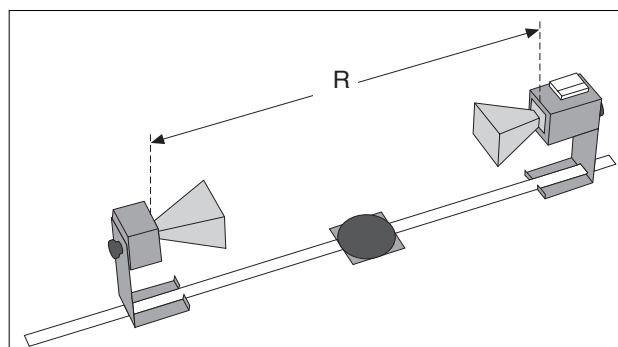

Figure 1.1 Equipment Setup

- ② Plug in the Transmitter and turn the INTENSITY selection switch on the Receiver from OFF to 10X. (The LEDs should light up on both units.)
- ③ Adjust the Transmitter and Receiver so the distance between the source diode in the Transmitter and the detector diode in the Receiver (the distance labeled **R** in Figure 1.1) is 40 cm (see Figure 1.2 for location of points of transmission and reception). The diodes are at the locations marked "T" and "R" on the bases. Adjust the INTENSITY and VARIABLE SENSITIVITY dials on the Receiver so that the meter reads 1.0 (full scale).

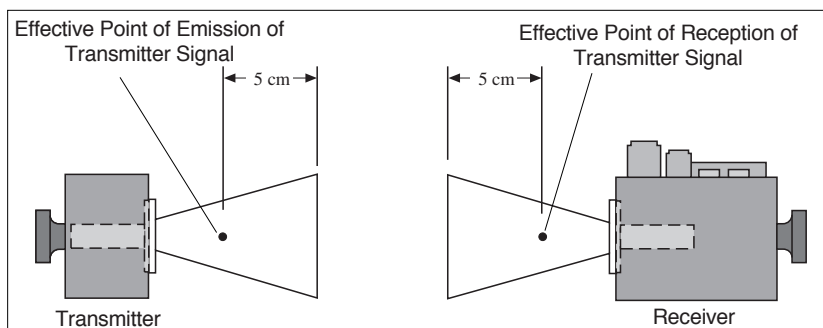

Figure 1.2 Equipment Setup

- ④ Set the distance **R** to each of the values shown in Table 1.1. For each value of **R**, record the meter reading. (Do not adjust the Receiver controls between measurements.) After making the measurements, perform the calculations shown in the table.
- ⑤ Set **R** to some value between 70 and 90 cm. While watching the meter, slowly decrease the distance between the Transmitter and Receiver. Does the meter deflection increase steadily as the distance decreases?

Table 1.1

R (cm)	Meter Reading (M)	M X R (cm)	M X R ² (cm ²)
40	1.0	40	1600
50			
60			
70			
80			
90			
100			

- ⑥ Set **R** to between 50 and 90 cm. Move a Reflector, its plane parallel to the axis of the microwave beam, toward and away from the beam axis, as shown in Figure 1.3. Observe the meter readings. Can you explain your observations in steps 5 and 6? Don't worry if you can't; you will have a chance to investigate these phenomena more closely in Experiments 3 and 8, later in this manual. For now just be aware of the following:

► **IMPORTANT:** Reflections from nearby objects, including the table top, can affect the results of your microwave experiments. To reduce the effects of extraneous reflections, keep your experiment table clear of all objects, especially metal objects, other than those components required for the current experiment.

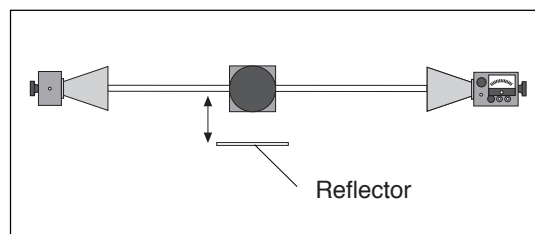

Figure 1.3 Reflections

- ⑦ Loosen the hand screw on the back of the Receiver and rotate the Receiver as shown in Figure 1.4. This varies the polarity of maximum detection. (Look into the receiver horn and notice the alignment of the detector diode.) Observe the meter readings through a full 360 degree rotation of the horn. A small mirror may be helpful to view the meter reading as the receiver is turned. At what polarity does the Receiver detect no signal?

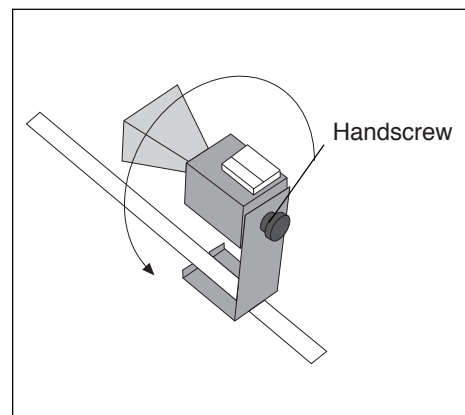

Figure 1.4 Polarization

Try rotating the Transmitter horn as well. When finished, reset the Transmitter and Receiver so their polarities match (e.g., both horns are horizontal or both horns are vertical).

- ⑧ Position the Transmitter so the output surface of the horn is centered directly over the center of the Degree Plate of the Goniometer arm (see Figure 1.5). With the Receiver directly facing the Transmitter and as far back on the Goniometer arm as possible, adjust the Receiver controls for a meter reading of 1.0. Then rotate the rotatable arm of the Goniometer as shown in the figure. Set the angle of rotation (measured relative to the 180-degree point on the degree scale) to each of the values shown in Table 1.2, and record the meter reading at each setting.

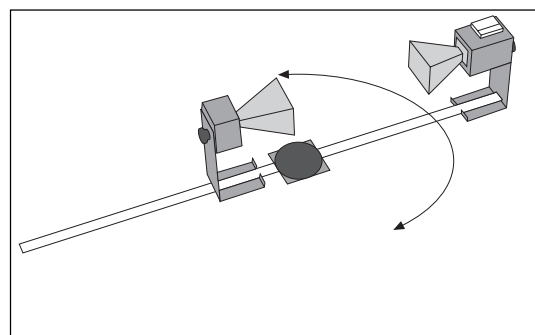

Figure 1.5 Signal Distribution

Table 1.2

Angle of Receiver	Meter Reading	Angle of Receiver	Meter Reading	Angle of Receiver	Meter Reading
0°		70°		140°	
10°		80°		150°	
20°		90°		160°	
30°		100°		170°	
40°		110°		180°	
50°		120°			
60°		130°			

Questions

- ① The electric field of an electromagnetic wave is inversely proportional to the distance from the wave source
(i.e., $E = 1/R$). Use your data from step 4 of the experiment to determine if the meter reading of the Receiver is directly proportional to the electric field of the wave.
- ② The intensity of an electromagnetic wave is inversely proportional to the square of the distance from the wave source (i.e., $I = 1/R^2$). Use your data from step 4 of the experiment to determine if the meter reading of the Receiver is directly proportional to the intensity of the wave.
- ③ Considering your results in step 7, to what extent can the Transmitter output be considered a spherical wave? - A plane wave?

Notes

Experiment 2: Reflection

EQUIPMENT NEEDED:

- Transmitter
- Goniometer
- Receiver
- Metal Reflector
- Rotating Component Holder

Procedure

- ① Arrange the equipment as shown in figure 2.1 with the Transmitter attached to the fixed arm of the Goniometer. Be sure to adjust the Transmitter and Receiver to the same polarity; the horns should have the same orientation as shown.
- ② Plug in the Transmitter and turn the Receiver INTENSITY selection switch to 30X.
- ③ The angle between the incident wave from the Transmitter and a line normal to the plane of the Reflector is called the **Angle of Incidence** (see Figure 2.2). Adjust the Rotating Component Holder so that the Angle of Incidence equals 45-degrees.
- ④ Without moving the Transmitter or the Reflector, rotate the movable arm of the Goniometer until the meter reading is a maximum. The angle between the axis of the Receiver horn and a line normal to the plane of the Reflector is called the **Angle of Reflection**.
- ⑤ Measure and record the angle of reflection for each of the angles of incidence shown in Table 2.1.

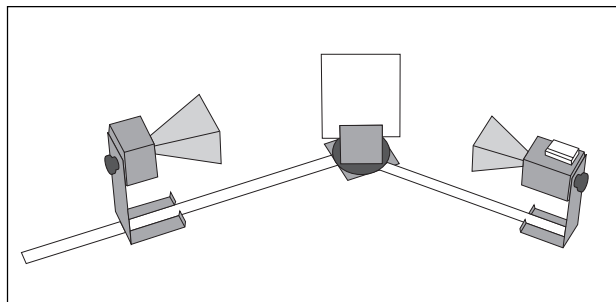

Figure 2.1 Equipment Setup

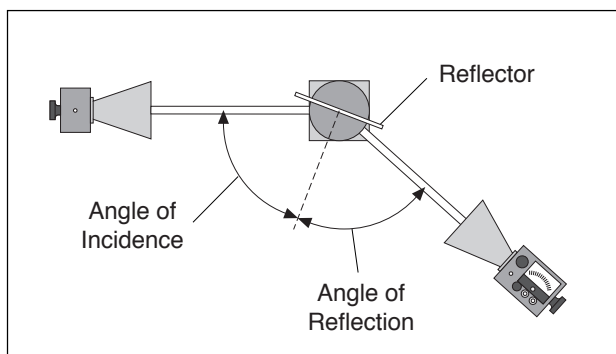

Figure 2.2 Angles of Incidence and Reflection

► **NOTE:** At various angle settings the Receiver will detect both the reflected wave and the wave coming directly from the Transmitter, thus giving misleading results. Determine the angles for which this is true and mark the data collected at these angles with an asterisk "*".

Table 2.1

Angle of Incidence	Angle of Reflection
20°	
30°	
40°	
50°	
60°	
70°	
80°	
90°	

Questions

- ① What relationship holds between the angle of incidence and the angle of reflection? Does this relationship hold for all angles of incidence?
- ② In measuring the angle of reflection, you measured the angle at which a maximum meter reading was found. Can you explain why some of the wave reflected into different angles? How does this affect your answer to question 1?
- ③ Ideally you would perform this experiment with a perfect plane wave, so that all the Transmitter radiation strikes the Reflector at the same angle of incidence. Is the microwave from the Transmitter a perfect plane wave (see Experiment 1, step 7)? Would you expect different results if it were a perfect plane wave? Explain.

Questions for Additional Experimentation

- ① How does reflection affect the intensity of the microwave? Is all the energy of the wave striking the Reflector reflected? Does the intensity of the reflected signal vary with the angle of incidence?
- ② Metal is a good reflector of microwaves. Investigate the reflective properties of other materials. How well do they reflect? Does some of the energy pass through the material? Does the material absorb some of it? Compare the reflective properties of conductive and non-conductive materials.

Experiment 3: Standing Waves - Measuring Wavelengths

► **NOTE:** This experiment is best performed using the PASCO Microwave Detector Probe (Model ME-9319), as described in Method A below. However, for those without a probe, Method B may be used, although in this Method λ can not be measured directly from the standing wave pattern.

EQUIPMENT NEEDED:

- | | |
|------------------------|--------------------------------------|
| – Transmitter | – Goniometer |
| – Receiver | – Reflector (1) |
| – Component Holder (2) | – Microwave Detector Probe (ME-9319) |

Introduction

When two electromagnetic waves meet in space, they superpose. Therefore, the total electric field at any point is the sum of the electric fields created by both waves at that point. If the two waves travel at the same frequency but in opposite direction they form a standing wave. Nodes appear where the fields of the two waves cancel and antinodes where the superposed field oscillates between a maximum and a minimum. The distance between nodes in the standing wave pattern is just 1/2 the wavelength (λ) of the two waves.

Procedure

Method A

In this experiment, you will reflect the wave from the Transmitter back upon itself, creating a standing wave pattern. By measuring the distance between nodes in the pattern and multiplying by two, you can determine the wavelength of the microwave radiation.

- ① Arrange the equipment as shown in Figure 3.1.
- ② Plug the Detector Probe into the side connector on the Receiver. Face the Receiver horn directly away from the Transmitter so that none of the microwave signal enters the horn. Adjust the Receiver controls as needed to get a strong meter reading.
- ③ Slide the Probe along the Goniometer arm (no more than a centimeter or two) until the meter shows a maximum reading. Then slide the Reflector (again, no more than a centimeter or two) to find a maximum meter reading. Continue making slight adjustments to the Probe and Reflector positions until the meter reading is as high as possible.
- ④ Now find a node of the standing wave pattern by adjusting the Probe until the meter reading is a minimum. Record the Probe Position along the metric scale on the Goniometer arm.

Initial Probe Position = _____.

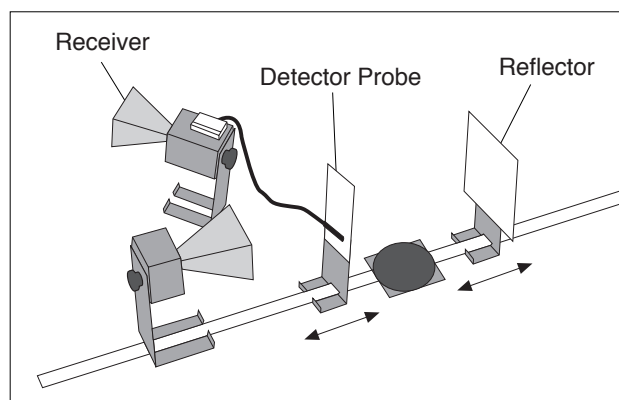

Figure 3.1 Equipment Setup

- ⑤) While watching the meter, slide the Probe along the Goniometer arm until the Probe has passed through at least 10 antinodes and returned to a node. Record the new position of the Probe and the number of antinodes that were traversed.

Antinodes Traversed= _____.

Final Probe Position = _____.

- ⑥ Use your data to calculate λ , the wavelength of the microwave radiation.

λ = _____.

- ⑦ Repeat your measurements and recalculate λ .

Initial Probe Position = _____.

Antinodes Traversed = _____.

Final Probe Position = _____.

λ = _____.

Questions

- ① Use the relationship $velocity = \lambda v$ to calculate the frequency of the microwave signal (assuming velocity of propagation in air is 3×10^8 m/sec).

(v = the expected frequency of the microwave radiation -10.525 GHz).

Method B

- ① Set up the equipment as shown in Figure 3.2. Adjust the Receiver controls to get a full-scale meter reading with the Transmitter and Receiver as close together as possible. Slowly move the Receiver along the Goniometer arm, away from the Transmitter. How does this motion effect the meter reading?

The microwave horns are not perfect collectors of microwave radiation. Instead, they act as partial reflectors, so that the radiation from the Transmitter reflects back and forth between the Transmitter and Reflector horns, diminishing in amplitude at each pass. However, if the distance between the Transmitter and Receiver diodes is equal to $n\lambda/2$, (where n is an integer and λ is the wavelength of the radiation) then all the multiply-reflected waves entering the Receiver horn will be in phase with the primary transmitted wave. When this occurs, the meter reading will be a maximum. (The distance between adjacent positions in order to see a maximum is therefore $\lambda/2$.)

- ② Slide the Receiver one or two centimeters along the Goniometer arm to obtain a maximum meter reading. Record the Receiver position along the metric scale of the Goniometer arm.

Initial Position of Receiver = _____.

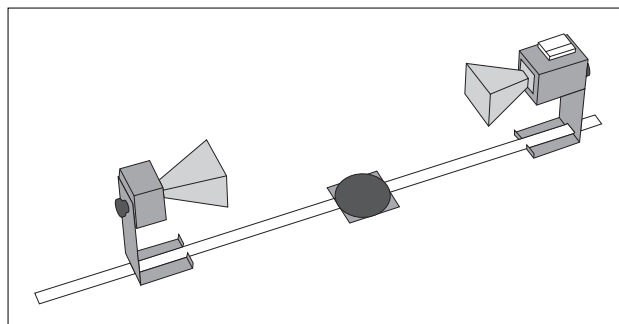

Figure 3.2 Equipment Setup

- ③ While watching the meter, slide the Receiver away from the Transmitter. Do not stop until the Receiver passed through at least 10 positions at which you see a minimum meter reading and it returned to a position where the reading is a maximum. Record the new position of the Receiver and the number of minima that were traversed.

Minima Traversed= _____.

Final Receiver Position = _____.

- ④ Use the data you have collected to calculate the wavelength of the microwave radiation.

$\lambda =$ _____.

- ⑤ Repeat your measurements and recalculate λ .

Initial Position of Receiver = _____.

Minima Traversed = _____.

Final Receiver Position = _____.

$\lambda =$ _____.

Questions

- ① Use the relationship $velocity = \lambda \nu$ to calculate the frequency of the microwave signal (assuming velocity of propagation in air is 3×10^8 m/sec).
(ν = the expected frequency of the microwave radiation -10.525 GHz).

<i>Notes</i>

Experiment 4: Refraction Through a Prism

EQUIPMENT NEEDED:

- Transmitter
- Goniometer
- Receiver
- Rotating Table
- Ethafoam Prism mold with styrene pellets
- Protractor

Introduction

An electromagnetic wave usually travels in a straight line. As it crosses a boundary between two different media, however, the direction of propagation of the wave changes. This change in direction is called **Refraction**, and it is summarized by a mathematical relationship known as the Law of Refraction (otherwise known as Snell's Law):

$$n_1 \sin \theta_1 = n_2 \sin \theta_2;$$

where θ_1 is the angle between the direction of propagation of the incident wave and the normal to the boundary between the two media, and θ_2 is the corresponding angle for the refracted wave (see Figure 4.1). Every material can be described by a number n , called its **Index of Refraction**. This number indicates the ratio between the speed of electromagnetic waves in vacuum and the speed of electromagnetic waves in the material, also called the medium. In general, the media on either side of a boundary will have different indices of refraction. Here they are labeled n_1 and n_2 . It is the difference between indices of refraction (and the difference between wave velocities this implies) which causes “bending”, or refraction of a wave as it crosses the boundary between two distinct media.

In this experiment, you will use the law of refraction to measure the index of refraction for styrene pellets.

Procedure

- ① Arrange the equipment as shown in Figure 4.2. Rotate the empty prism mold and see how it effects the incident wave. Does it reflect, refract, or absorb the wave?
- ② Fill the prism mold with the styrene pellets. To simplify the calculations, align the face of the prism that is nearest to the Transmitter perpendicular to the incident microwave beam.
- ③ Rotate the movable arm of the Goniometer and locate the angle θ at which the refracted signal is a maximum.

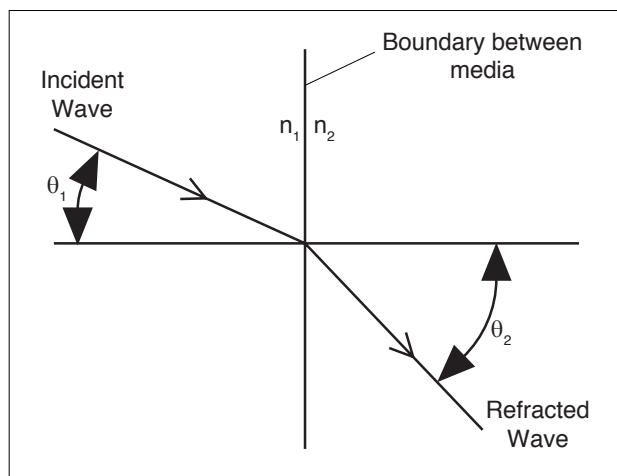

Figure 4.1 Angles of Incidence and Refraction

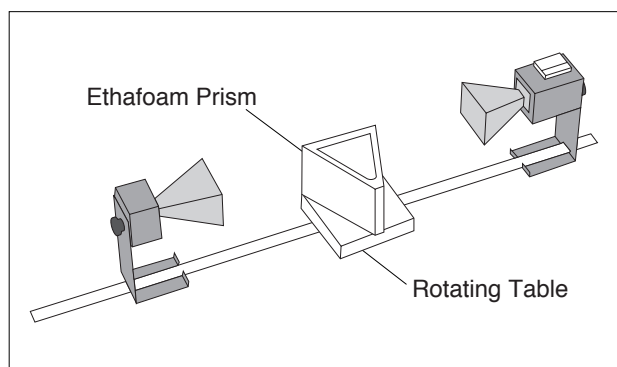

Figure 4.2 Equipment Setup

►NOTE: θ is just the angle that you read directly from the Degree Scale of the Goniometer.

$\theta =$ _____.

- ④ Using the diagram shown in Figure 4.3, determine θ_1 and use your value of θ to determine θ_2 . (You will need to use a protractor to measure the Prism angles.)

$\theta_1 =$ _____.

$\theta_2 =$ _____.

- ⑤ Plug these values into the Law of Refraction to determine the value of n_1/n_2 .

$n_1/n_2 =$ _____.

- ⑥ The index of refraction for air is equal to 1.00. Use this fact to determine n_1 , the index of refraction for the styrene pellets.

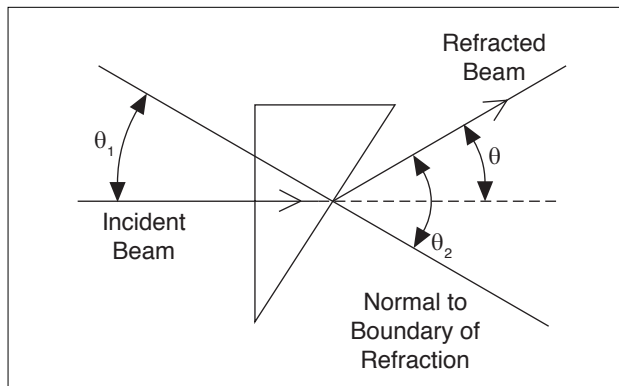

Figure 4.3 Geometry of Prism Refraction

Questions

- ① In the diagram of Figure 4.3, the assumption is made that the wave is unrefracted when it strikes the first side of the prism (at an angle of incidence of 0°). Is this a valid assumption?
- ② Using this apparatus, how might you verify that the index of refraction for air is equal to one.
- ③ Would you expect the refraction index of the styrene pellets in the prism mold to be the same as for a solid styrene prism?

Experiment 5: Polarization

EQUIPMENT NEEDED:

- | | |
|-----------------|-----------------------|
| -Transmitter | -Receiver |
| -Goniometer | -Component Holder (1) |
| -Polarizer (1). | |

Introduction

The microwave radiation from the Transmitter is **linearly polarized** along the Transmitter diode axis (i.e., as the radiation propagates through space, its electric field remains aligned with the axis of the diode). If the Transmitter diode were aligned vertically, the electric field of the transmitted wave would be vertically polarized, as shown in Figure 5.1. If the detector diode were at an angle θ to the Transmitter diode, as shown in Figure 5.2, it would only detect the component of the incident electric field that was aligned along its axis. In this experiment you will investigate the phenomenon of polarization and discover how a polarizer can be used to alter the polarization of microwave radiation.

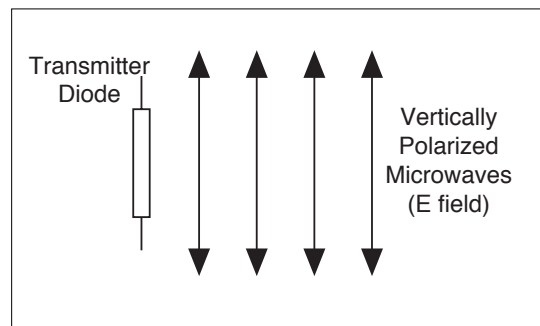

Figure 5.1 Vertical Polarization

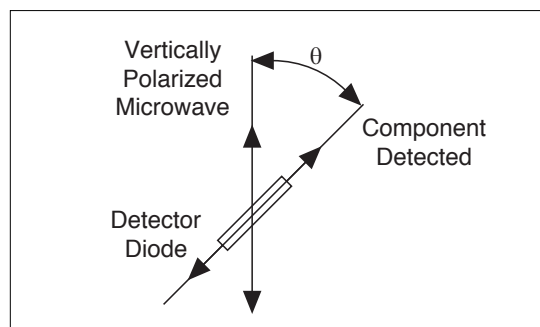

Figure 5.2 Detecting Polarized Radiation

Procedure

- ① Arrange the equipment as shown in Figure 5.3 and adjust the Receiver controls for nearly full-scale meter deflection.
- ② Loosen the hand screw on the back of the Receiver and rotate the Receiver in increments of ten degrees. At each rotational position, record the meter reading in Table 5.1.
- ③ What happens to the meter readings if you continue to rotate the Receiver beyond 180-degrees?

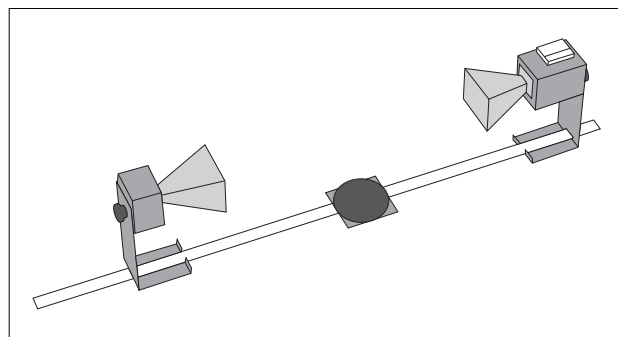

Figure 5.3 Equipment Setup

Table 5.1

Angle of Receiver	Meter Reading	Angle of Receiver	Meter Reading	Angle of Receiver	Meter Reading
0°		70°		140°	
10°		80°		150°	
20°		90°		160°	
30°		100°		170°	
40°		110°		180°	
50°		120°			
60°		130°			

- ④ Set up the equipment as shown in Figure 5.4. Reset the Receiver's angle to 0-degrees (the horns should be oriented as shown with the longer side horizontal).
- ⑤ Record the meter reading when the Polarizer is aligned at 0, 22.5, 45, 67.5 and 90-degrees with respect to the horizontal.
- ⑥ Remove the Polarizer slits. Rotate the Receiver so the axis of its horn is at right angles to that of the Transmitter. Record the meter reading. Then replace the Polarizer slits and record the meter readings with the Polarizer slits horizontal, vertical, and at 45-

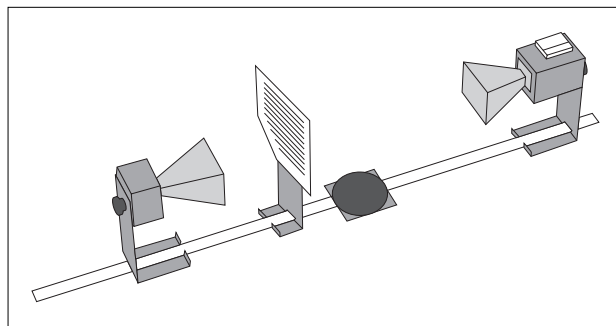

Figure 5.4 Equipment Setup

Angle of Polarizer	Meter Reading
0° (Horiz.)	
22.5°	
45°	
67.5°	
90° (Vert.)	

Angle of Slits	Meter Reading
Horizontal	
Vertical	
45°	

degrees.

Questions

- ① If the Receiver meter reading (M) were directly proportional to the electric field component (E) along its axis, the meter would read the relationship $M = M_0 \cos\theta$ (where θ is the angle between the detector and Transmitter diodes and M_0 is the meter reading when $\theta = 0$). (See Figure 5.2). Graph your data from step 2 of the experiment. On the same graph, plot the relationship $M_0 \cos\theta$. Compare the two graphs.
- ② The intensity of a linearly polarized electromagnetic wave is directly proportional to the square of the electric field (e.g., $I = kE^2$). If the Receiver's meter reading was directly proportional to the incident microwave's intensity, the meter would read the relationship $M = M_0 \cos^2\theta$. Plot this relationship on your graph from question 1. Based on your graphs, discuss the relationship between the meter reading of the Receiver and the polarization and magnitude of the incident microwave.
- ③ Based on your data from step 5, how does the Polarizer affect the incident microwave?
- ④ Can you explain the results of step 6 of the experiment. How can the insertion of an additional polarizer increase the signal level at the detector? (**HINT:** Construct a diagram like that shown in Figure 5.2 showing (1) the wave from the Transmitter; (2) the wave after it passes through the Polarizer; and (3) the component detected at the detector diode.)

Experiment 6: Double-Slit Interference

EQUIPMENT NEEDED:

- Transmitter, Receiver
- Component Holder
- Slit Extender Arm
- Wide Slit Spacer
- Goniometer, Rotating
- Metal Reflectors (2)
- Narrow Slit Spacer

Introduction

In Experiment 3, you saw how two waves moving in opposite directions can superpose to create a standing wave pattern. A somewhat similar phenomenon occurs when an electromagnetic wave passes through a two-slit aperture. The wave diffracts into two waves which superpose in the space beyond the apertures. Similar to the standing wave pattern, there are points in space where maxima are formed and others where minima are formed.

With a double slit aperture, the intensity of the wave beyond the aperture will vary depending on the angle of detection. For two thin slits separated by a distance d , maxima will be found at angles such that $d \sin\theta = n\lambda$. (Where θ = the angle of detection, λ = the wavelength of the incident radiation, and n is any integer) (See Figure 6.1). Refer to a textbook for more information about the nature of the double-slit diffraction pattern.

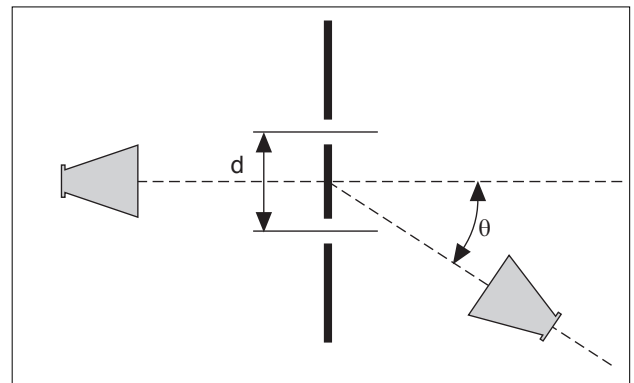

Figure 6.1 Double-Slit Interference

Procedure

- ① Arrange the equipment as shown in Figure 6.2. Use the Slit Extender Arm, two Reflectors, and the Narrow Slit Spacer to construct the double slit. (We recommend a slit width of about 1.5 cm.) Be precise with the alignment of the slit and make the setup as symmetrical as possible.
- ② Adjust the Transmitter and Receiver for vertical polarization (0°) and adjust the Receiver controls to give a full-scale reading at the lowest possible amplification.
- ③ Rotate the rotatable Goniometer arm (on which the Receiver rests) slowly about its axis. Observe the meter readings.
- ④ Reset the Goniometer arm so the Receiver directly faces the Transmitter. Adjust the Receiver controls to obtain a meter reading of 1.0. Now set the angle θ to each of the values shown in Table 6.1. At each setting record the meter reading in the table. (In places where the meter reading changes significantly between angle settings, you may find it useful to investigate the signal level at intermediate angles.)

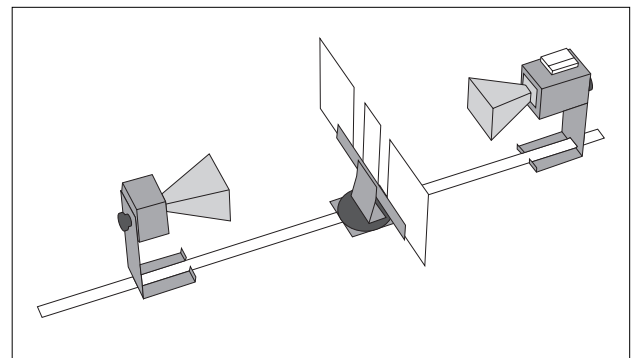

Figure 6.2 Equipment Setup

Table 6.1

⑤) Keep the slit widths the same, but change the distance between the slits by using the Wide Slit Spacer instead of the Narrow Slit Spacer. Because the Wide Slit Space is 50% wider than the Narrow Slit Spacer (90mm vs 60mm) move the Transmitter back 50% so that the microwave radiation at the slits will have the same relative intensity. Repeat the measurements. (You may want to try other slit spacings as well.)

Angle	Meter Reading	Angle	Meter Reading
0°		45°	
5°		50°	
10°		55°	
15°		60°	
20°		65°	
25°		70°	
30°		75°	
35°		80°	
40°		85°	

Questions

- ① From your data, plot a graph of meter reading versus θ . Identify the angles at which the maxima and minima of the interference pattern occur.
- ② Calculate the angles at which you would expect the maxima and minima to occur in a standard two-slit diffraction pattern—maxima occur wherever $d \sin\theta = n\lambda$, minima occur wherever $d \sin\theta = n\lambda/2$. (Check your textbook for the derivation of these equations, and use the wavelength measured in experiment 3.) How does this compare with the locations of your observed maxima and minima? Can you explain any discrepancies? (What assumptions are made in the derivations of the formulas and to what extent are they met in this experiment?)
- ③ Can you explain the relative drop in intensity for higher order maxima? Consider the single-slit diffraction pattern created by each slit. How do these single slit patterns affect the overall interference pattern?

► NOTE:

- ① Wavelength at 10.525 GHz = 2.85 cm.
- ② The experimenter’s body position may affect the results.

Experiment 7: Lloyd's Mirror

EQUIPMENT NEEDED:

- | | |
|--|---|
| <ul style="list-style-type: none"> - Transmitter - Goniometer - Component Holder - Meter Stick | <ul style="list-style-type: none"> - Receiver - Fixed Arm Assembly - Reflector (1) |
|--|---|

Introduction

In earlier experiments, such as 3 and 6, you observed how a single electromagnetic wave can be diffracted into two waves and, when the two components join back together, they form an interference pattern. Lloyd's Mirror is another example of this phenomenon. Just as with the other interference patterns you have seen, this interference pattern provides a convenient method for measuring the wavelength of the radiation.

Figure 7.1 is a diagram for Lloyd's mirror. An electromagnetic wave from point source **A** is detected at point **C**. Some of the electromagnetic wave, of course, propagates directly between point **A** and **C**, but some reaches **C** after being reflected at point **B**. A maximum signal will be detected when the two waves reach the detector in phase. Assuming that the diagram shows a setup for a maximum signal, another maximum will be found when the Reflector is moved back so the path length of the reflected beam is $AB + BC + \lambda$.

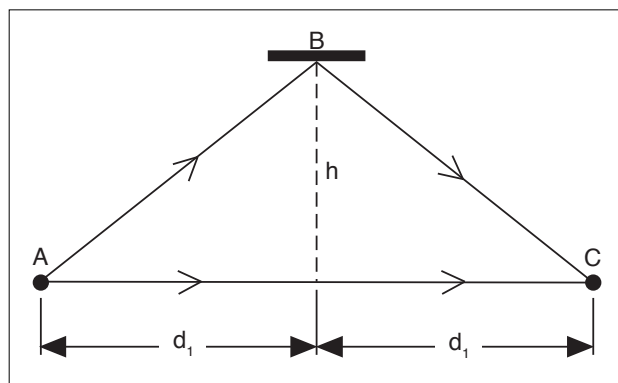

Figure 7.1 Lloyd's Mirror

Procedure

- ① Arrange the equipment as shown in Figure 7.2. For best results, the Transmitter and Receiver should be as far apart as possible. Be sure the Receiver and Transmitter are equidistant (d_1) from the center of the Goniometer degree plate and that the horns are directly facing each other. (See Figure 7.3 for location of effective points of transmission and reception). Also be sure that the surface of the Reflector is parallel to the axis of the Transmitter and Receiver horns.
- ② While watching the meter on the Receiver, slowly slide the Reflector away from the Degree Plate. Notice how the meter reading passes through a series of minima and maxima.
- ③ Find the Reflector position closest to the degree plate which produces a minimum meter reading.
- ④ Measure and record h_1 , the distance between the center of the degree plate and the surface of the Reflector.

$h_1 =$ _____.

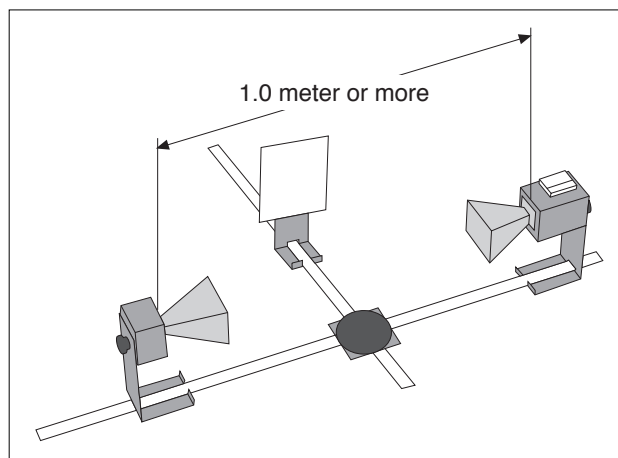

Figure 7.2 Equipment Setup

⑤) Slowly slide the Reflector away from the degree plate until the meter reading passes through a maximum and returns to a new minimum. Measure and record h_2 , the new distance between the center of the degree plate and the surface of the Reflector.

$h_2 =$ _____.

⑥ Measure d_1 the distance between the center of the degree scale and the Transmitter diode.

$d_1 =$ _____.

⑦ Use your collected data to calculate λ , the wavelength of the microwave radiation.

$\lambda =$ _____.

⑧ Change the distance between the Transmitter and Receiver and repeat your measurements.

$h_1 =$ _____.

$h_2 =$ _____.

$d_1 =$ _____.

$\lambda =$ _____.

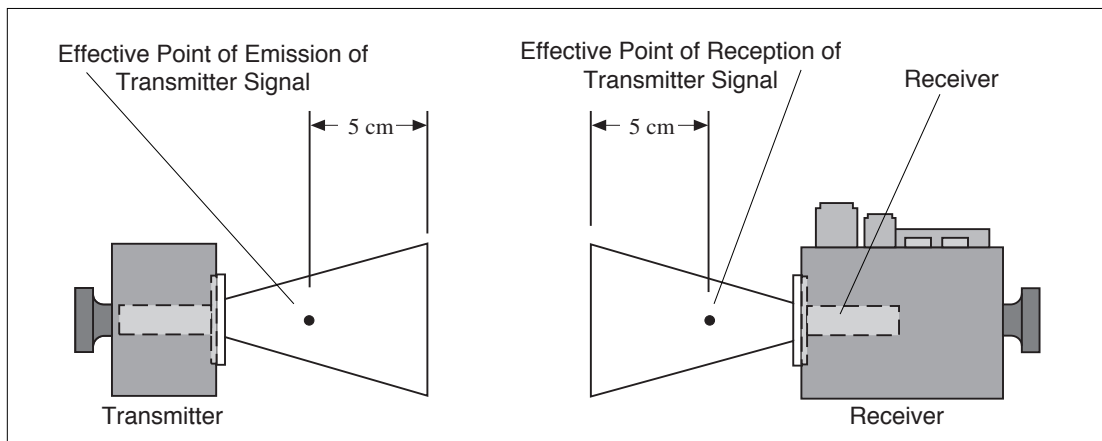

Figure 7.3 Transmission and Reception Points

Questions

① What is the advantage in having the effective transmission and reception points equidistant from the center of the degree plate in this experiment?

► **NOTE:** Don't stand in front of the apparatus while conducting the experiment. Your body acts as a reflector. Therefore, try to stand to one side behind the plane of the antenna horn.

Experiment 8: Fabry-Perot Interferometer

EQUIPMENT NEEDED:

- | | |
|--------------------------|-------------------------|
| - Transmitter | - Receiver |
| - Goniometer | - Component Holders (2) |
| - Partial Reflectors (2) | |

Introduction

When an electromagnetic wave encounters a partial reflector, part of the wave reflects and part of the wave transmits through the partial reflector. A Fabry-Perot Interferometer consists of two parallel partial reflectors positioned between a wave source and a detector (see Figure 8.1).

The wave from the source reflects back and forth between the two partial reflectors. However, with each pass, some of the radiation passes through to the detector. If the distance between the partial reflectors is equal to $n\lambda/2$, where λ is the wavelength of the radiation and n is an integer, then all the waves passing through to the detector at any instant will be in phase. In this case, a maximum signal will be detected by the Receiver. If the distance between the partial reflectors is not a multiple of $\lambda/2$, then some degree of destructive interference will occur, and the signal will not be a maximum.

Procedure

- ① Arrange the equipment as shown in Figure 8.1. Plug in the Transmitter and adjust the Receiver controls for an easily readable signal.
- ② Adjust the distance between the Partial Reflectors and observe the relative minima and maxima.
- ③ Adjust the distance between the Partial Reflectors to obtain a maximum meter reading. Record, d_1 , the distance between the reflectors.

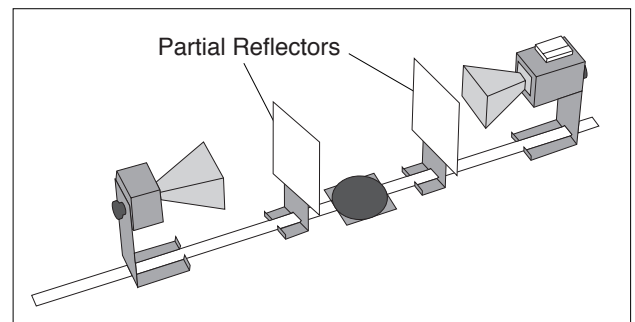

Figure 8.1 Fabry-Perot Interferometer

$d_1 =$ _____.

- ④ While watching the meter, slowly move one Reflector away from the other. Move the Reflector until the meter reading has passed through at least 10 minima and returned to a maximum. Record the number of minima that were traversed. Also record d_2 , the new distance between the Reflectors.

Minima traversed = _____.

$d_2 =$ _____.

- ⑤ Use your data to calculate λ , the wavelength of the microwave radiation.

$\lambda =$ _____.

- ⑥ Repeat your measurements, beginning with a different distance between the Partial Reflectors.

$d_1 =$ _____ . Minima traversed = _____ .

$d_2 =$ _____ . $\lambda =$ _____ .

Questions

- ① What spacing between the two Partial Reflectors should cause a minimum signal to be delivered to the Receiver?
- ② In an optical Fabry-Perot interferometer the interference pattern usually appears as a series of concentric rings. Do you expect such a pattern to occur here? Why? Check to see if there is one.

Experiment 9: Michelson Interferometer

EQUIPMENT NEEDED:

- | | |
|---|--|
| <ul style="list-style-type: none"> - Transmitter, - Goniometer, - Component Holders (2) - Partial Reflector (1) | <ul style="list-style-type: none"> - Receiver - Fixed Arm Assembly - Rotating Table, Reflectors (2) |
|---|--|

Introduction

Like the Fabry-Perot interferometer, the Michelson interferometer splits a single wave, then brings the constituent waves back together so that they superpose, forming an interference pattern. Figure 9.1 shows the setup for the Michelson interferometer. **A** and **B** are Reflectors and **C** is a Partial Reflector. Microwaves travel from the Transmitter to the Receiver over two different paths. In one path, the wave passes directly through **C**, reflects back to **C** from **A**, and then is reflected from **C** into the Receiver. In the other path, the wave reflects from **C** into **B**, and then back through **C** into the Receiver.

If the two waves are in phase when they reach the Receiver, a maximum signal is detected. By moving one of the Reflectors, the path length of one wave changes, thereby changing its phase at the Receiver so a maximum is no longer detected. Since each wave passes twice between a Reflector and the Partial Reflector, moving a Reflector a distance $\lambda/2$ will cause a complete 360-degree change in the phase of one wave at the Receiver. This causes the meter reading to pass through a minimum and return to a maximum.

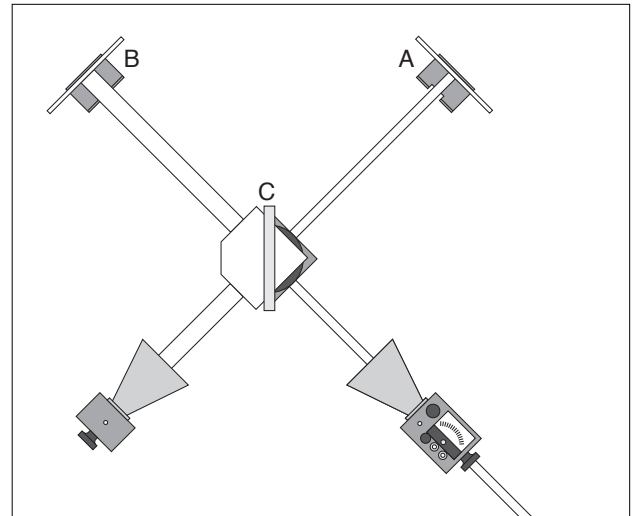

Figure 9.1 Michelson Interferometer

Procedure

- ① Arrange the equipment as shown in Figure 9.1. Plug in the Transmitter and adjust the Receiver for an easily readable signal.
- ② Slide Reflector **A** along the Goniometer arm and observe the relative maxima and minima of the meter deflections.
- ③ Set Reflector **A** to a position which produces a maximum meter reading. Record, x_1 , the position of the Reflector on the Goniometer arm.

$$x_1 = \underline{\hspace{4cm}}.$$

- ④ While watching the meter, slowly move Reflector **A** away from the Partial Reflector. Move the Reflector until the meter reading has passed through at least 10 minima and returned to a maximum. Record the number of minima that were traversed. Also record x_2 , the new position of Reflector **A** on the Goniometer arm.

$$\text{Minima traversed} = \underline{\hspace{4cm}}.$$

$$x_2 = \underline{\hspace{4cm}}.$$

- ⑤) Use your data to calculate λ , the wavelength of the microwave radiation.

$$\lambda = \underline{\hspace{2cm}}.$$

- ⑥ Repeat your measurements, beginning with a different position for Reflector **A**.

$$x_1 = \underline{\hspace{2cm}}.$$

$$\text{Minima traversed} = \underline{\hspace{2cm}}.$$

$$x_2 = \underline{\hspace{2cm}}.$$

$$\lambda = \underline{\hspace{2cm}}.$$

Questions

- ① You have used the interferometer to measure the wavelength of the microwave radiation. If you already knew the wavelength, you could use the interferometer to measure the distance over which the Reflector moved. Why would an optical interferometer (an interferometer using visible light rather than microwaves) provide better resolution when measuring distance than a microwave interferometer?

An Idea for Further Investigation

Place a cardboard box between the Partial Reflector and Reflector **A**. Move one of the reflectors until the meter deflection is a maximum. Slowly fill the box with styrene pellets while observing the meter deflections. On the basis of these observations, adjust the position of Reflector **A** to restore the original maximum. Measure the distance over which you adjusted the reflector. Also measure the distance traversed by the beam through the pellets. From this data, can you determine the styrene pellets' index of refraction at microwave frequencies? (The wavelength of electromagnetic radiation in a material is given by the relationship $\lambda = \lambda_0/n$; where λ is the wavelength, λ_0 is the wavelength in a vacuum, and n is the index of refraction of the material.) Try boxes of various widths. You might also try filling them with a different material.

Experiment 10: Fiber Optics

EQUIPMENT NEEDED:

- Transmitter
- Receiver
- Goniometer
- Tubular Plastic Bags
- Styrene Pellets

Introduction

Light can propagate through empty space, but it can also propagate well through certain materials, such as glass. In fiber optics, a thin, flexible glass tube functions as a transmission line for light from a laser, much as a copper wire can function as a transmission line for electrical impulses. In the same way that variation of the electrical impulses can carry information through the copper wire (for example as a phone message), variation in the intensity of the laser light can carry information through the glass tube.

Procedure

- ① Align the Transmitter and Receiver directly across from each other on the Goniometer, and adjust the Receiver controls for a readable signal.
- ② Fill a tubular plastic bag with styrene pellets (tie the end or use a rubber band). Place one end of the bag in the Transmitter horn. What happens to the meter reading? Now place the other end in the Receiver horn. How does the intensity of the detected signal compare to the intensity when the bag is not used?
- ③ Remove the plastic bag and turn the Rotatable Goniometer arm until no meter deflection appears. Place one end of the bag in the Transmitter horn, the other in the Receiver horn. Note the meter reading.
- ④ Vary the radius of curvature of the plastic bag. How does this effect the signal strength? Does the signal vary gradually or suddenly as the radial curvature of the plastic bag changes? Find the radius of curvature at which the signal begins to drop significantly.

Questions

- ① Check your textbook for information on Total Internal Reflection. Based on the radial curvature when the signal begins to show attenuation as it passes through the plastic bag, determine the angle of total internal reflection for the styrene pellets. Can you use this value to determine the index of refraction of the styrene pellets?
- ② Would you expect the plastic bag filled with styrene pellets to work the same with radiation at optical frequencies? Why?

Notes

Experiment 11: Brewster's Angle

EQUIPMENT NEEDED:

- | | |
|----------------------|------------------|
| - Transmitter | - Receiver |
| - Goniometer | - Rotating Table |
| - Polyethylene Panel | |

Introduction

When electromagnetic radiation passes from one media into another, some of the radiation usually reflects from the surface of the new medium. In this experiment, you will find that the magnitude of the reflected signal depends on the polarization of the radiation. In fact, at a certain angle of incidence—known as Brewster's Angle—there is an angle of polarization for which no radiation will be reflected. (Check your textbook for more information on Brewster's Angle.)

Procedure

- ① Arrange the equipment as shown in Figure 11.1, setting both the Transmitter and the Receiver for horizontal polarization (90°).
- ② Adjust the Panel so the angle of incidence of the microwave from the Transmitter is 20° . Rotate the Goniometer arm until the Receiver is positioned where it can detect the maximum signal reflected from the Panel. Adjust the Receiver controls for a mid-scale reading, and record the meter reading in Table 11.1.

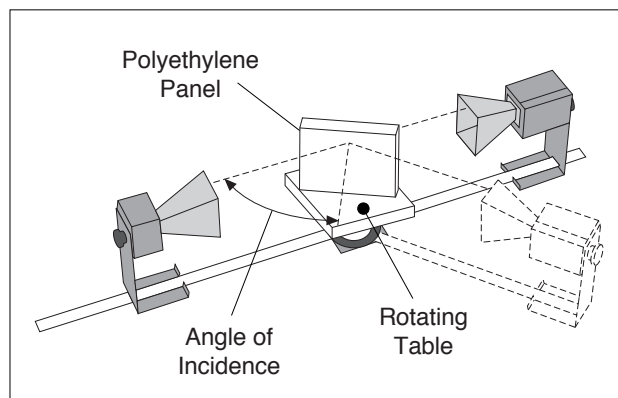

Figure 11.1 Equipment Setup

Table 11.1

Angle	Meter Reading (Horizontal Polarization)	Meter Reading (Vertical Polarization)
20°		
25°		
30°		
35°		
40°		
45°		
50°		
55°		
60°		
65°		
70°		
75°		

- ③ Without changing the angles between the transmitted beam, the Polyethylene Panel, and the Receiver, rotate both the Transmitter and the Receiver horns so they align for vertical polarization (0°). Record the new meter reading in the table.
- ④ Repeat steps 2 and 3, setting the angle of incidence to each of the values shown in the table below. At each point set the Transmitter and Receiver for horizontal polarization and record the meter reading; then set them for vertical polarization and record that reading as well.
- ⑤ Plot a graph of “Meter Reading” versus “Angle of Incidence”. Plot both the vertical and horizontal polarizations on the same graph. Label Brewster’s Angle—the angle at which the horizontally polarized wave does not reflect.

Questions

- ① Explain how Polaroid sun-glasses can be used to reduce the glare caused by the sun setting over a lake or the ocean. Should the glasses be designed to block vertically or horizontally polarized light?
- ② Could you use the microwave apparatus to locate Brewster’s Angle by examining the transmitted wave rather than the reflected wave? How?

Experiment 12: Bragg Diffraction

EQUIPMENT NEEDED:

- | | |
|--|--|
| <ul style="list-style-type: none"> - Transmitter - Goniometer - Cubic Lattice | <ul style="list-style-type: none"> - Receiver - Rotating Table |
|--|--|

Introduction

Bragg's Law provides a powerful tool for investigating crystal structure by relating the interplanar spacings in the crystal to the scattering angles of incident x-rays. In this experiment, Bragg's Law is demonstrated on a macroscopic scale using a cubic "crystal" consisting of 10-mm metal spheres embedded in an ethafoam cube.

Before performing this experiment, you should understand the theory behind Bragg Diffraction. In particular, you should understand the two criteria that must be met for a wave to be diffracted from a crystal into a particular angle. Namely, there is a plane of atoms in the crystal oriented with respect to the incident wave, such that:

- ① The angle of incidence equals the angle of reflection, and
- ② Bragg's equation, $2d\sin\theta = n\lambda$, is satisfied; where d is the spacing between the diffracting planes, θ is the grazing angle of the incident wave, n is an integer, and λ is the wavelength of the radiation.

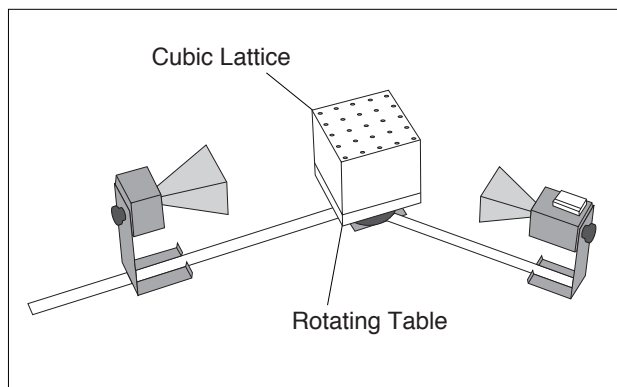

Figure 12.1 Equipment Setup

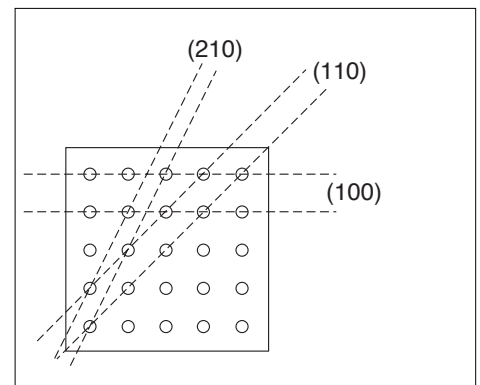

Figure 12.2 "Atomic" Planes of the Bragg Crystal

Procedure

- ① Arrange the equipment as shown in Figure 12.1.
- ② Notice the three families of planes indicated in Figure 12.2. (The designations (100), (110), and (210) are the Miller indices for these sets of planes.) Adjust the Transmitter and Receiver so that they directly face each other. Align the crystal so that the (100) planes are parallel to the incident microwave beam. Adjust the Receiver controls to provide a readable signal. Record the meter reading.

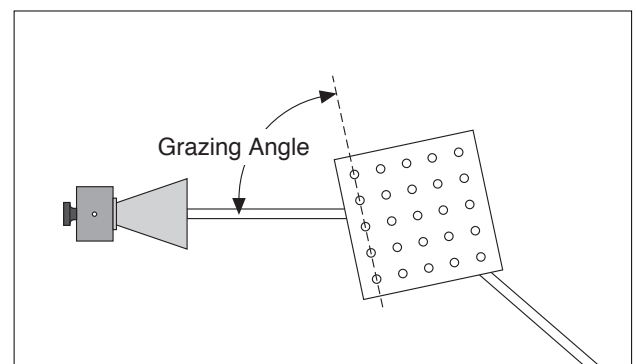

Figure 12.3 Grazing Angle

- ③ Rotate the crystal (with the rotating table) one degree clockwise and the Rotatable Goniometer arm two degrees clockwise. Record the grazing angle of the incident beam and the meter reading. (The grazing angle is the complement of the angle of incidence. It is measured with respect to the plane under investigation, **NOT** the face of the cube; see Figure 12.3.)
- ④ Continue in this manner, rotating the Goniometer arm two degrees for every one degree rotation of the crystal. Record the angle and meter reading at each position. (If you need to adjust the INTENSITY setting on the Receiver, be sure to indicate that in your data.)
- ⑤) Graph the relative intensity of the diffracted signal as a function of the grazing angle of the incident beam. At what angles do definite peaks for the diffracted intensity occur?

Use your data, the known wavelength of the microwave radiation (2.85 cm), and Bragg's Law to determine the spacing between the (100) planes of the Bragg Crystal. Measure the spacing between the planes directly, and compare with your experimental determination.

- ⑥ If you have time, repeat the experiment for the (110) and (210) families of planes.

Questions

- ① What other families of planes might you expect to show diffraction in a cubic crystal? Would you expect the diffraction to be observable with this apparatus? Why?
- ② Suppose you did not know beforehand the orientation of the "inter-atomic planes" in the crystal. How would this affect the complexity of the experiment? How would you go about locating the planes?

The Bragg Diffraction Experiment was developed by Dr. Harry Meiners of Rensselaer Polytechnic Institute.

Teacher's Guide

Exp 1 – Introduction to the System

Notes – on Procedure

- ④ The meter reading does not vary with distance in an entirely predictable way, since the microwaves form standing waves between the transmitter and receiver at certain distances. In addition, the meter is not directly related to either the electric field or the intensity of the incident beam. The meter is useful for measuring relative intensity at a constant distance, polarization, and so on.

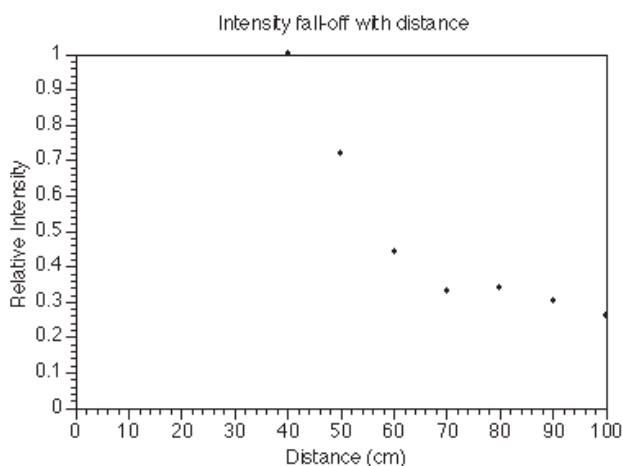

- ⑤ The meter reading oscillates as the distance is decreased. (See experiment 3, method B)
- ⑥ The presence of a reflector increases the meter reading.
- ⑦ The receiver detects no signal when the transmitter and receiver are at 90° to each other.

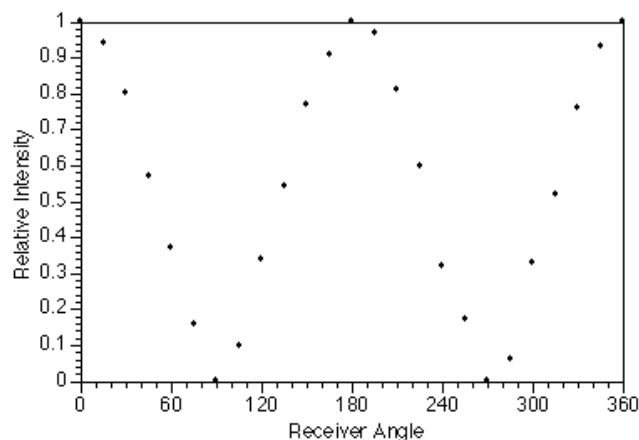

- ⑧ The transmitter has a roughly gaussian output distribution, with the $1/e$ points at about $\pm 20^\circ$.

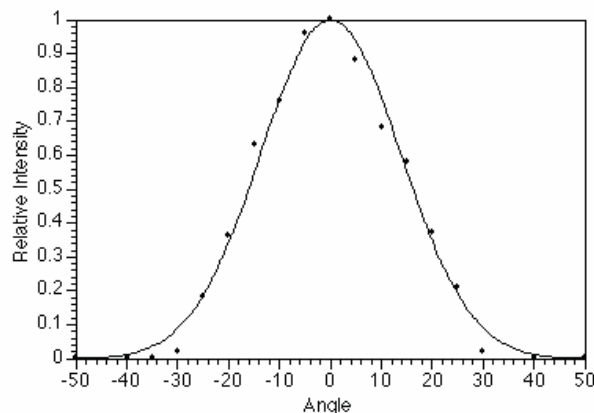

There is no significant difference between the output distributions in the horizontal and vertical orientations

Answers – to Questions

- ①/② The meter reading is not proportional to either the electric field or the intensity.
- ③ The transmitter output is more plane wave than spherical wave, but it has characteristics of both.

Exp 2 – Reflection

Notes – on Procedure

⑤

<u>Angle of Incidence</u>	<u>Angle of Reflection</u>
20°	23°
30°	31°
40°	41°
50°	54°
60°	63°
70°	85°*
80°	78°*
90°	70°*

The last three points are suspect, due to the spread in the output pattern of the transmitter. See experiment 1, part 8.

Answers – to Questions

- ① The angle of incidence equals the angle of reflection. This does hold for all angles, although it is not clear in this experiment due to the spread in the output pattern.
- ② Some of the wave appeared to reflect into different angles; particularly when the angle of incidence was 70° or 90°. This is actually a diffraction effect, not reflection.
- ③ The transmitter does not produce a perfect plane wave, and this does affect the results.

Answers – to Questions for Additional Experimentation

- ① Intensity of the reflection does vary with the angle of incidence; from this we can deduce that the reflector is not 100% efficient.
- ② In general, conductors will reflect the microwaves much better than non-conductors.

Exp 3– Standing Waves - Measuring Wavelengths

Notes – on Procedure

► **NOTE:** There are two different methods described in this lab. The first method, using the Microwave Detector Probe, is the easier of the two; but either will work.

Method A

<u># of antinode</u>	<u>Distance</u>	<u>Wavelength</u>
5	7.1	2.84
10	14.1	2.82
15	20.0	2.67
19	27.5	2.89

Average: 2.81

Frequency: 1.07E+10

Method B

<u># of antinode</u>	<u>Distance</u>	<u>Wavelength</u>
10	13.3	2.66
15	20.5	2.73

Average: 2.70

Frequency: 1.11E+10

(Fewer points were taken due to the limited resolution of this method.)

Answers – to Questions

The value obtained by the first method was 1.5% off, and the second was 5.6% off. If it is possible to take more data points on the second method, you may get better results.

Exp 4– Refraction Through a Prism**Notes – on Procedure**

- ① The empty foam prism absorbs the radiation by a very slight amount.
- ③ $\theta = 7^\circ (\pm 1^\circ)$
- ④ $\theta_1 = 22^\circ$
 $\theta_2 = 29^\circ$
- ⑤/⑥ Our experimental value was: $n_1 = 1.3 \pm 0.05$

Answers – to Questions

- ① This assumption is valid. According to Snell's law, if the angle of incidence is zero, the angle of refraction is zero also.

- ③ The index for a solid styrene prism would be higher, due to the greater “optical” density of the solid material.

General Notes

- ① The prism mold may be filled with other materials as well. We used water for one such test. The water absorbs most of the microwave energy (this is how a microwave oven works) but enough gets through that it may be measured on the most sensitive scale of the receiver. We found that $n = 1.4 \pm 0.05$.
- ② The jar that the styrene pellets are shipped in has been used as a cylindrical lens, with limited success.

Exp 5– Polarization

Notes – on Procedure

②

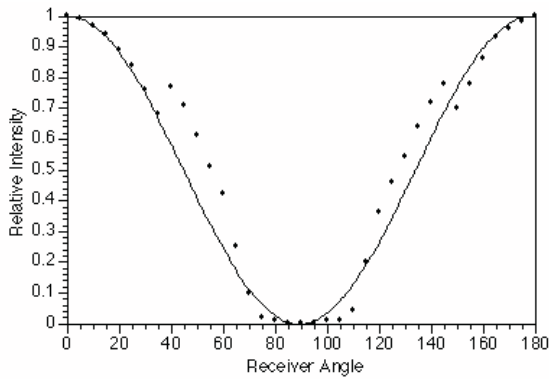

►NOTE: There is a consistent “glitch” in the data at a polarization angle of about 40 and 140 degrees which is not entirely explained by the non-linearity of the receiver. (This glitch is also present when the polarizer slits are used in part 5 of this lab.) If you have an explanation of why this occurs, please let us know.

③ Continued rotation of the receiver results in duplication of the pattern above.

⑤

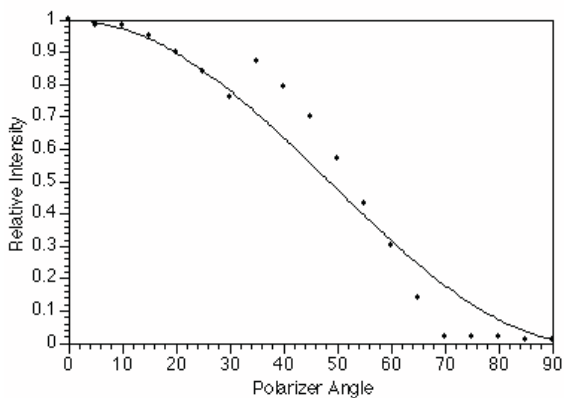

⑥ The meter reading is zero when the polarizer slits are oriented vertically or horizontally. When the slits are at 45°, the meter reads about 30% of its maximum value for that distance.

Answers – to Questions

①/ ② The meter reading more closely matches the intensity than it does the electric field.

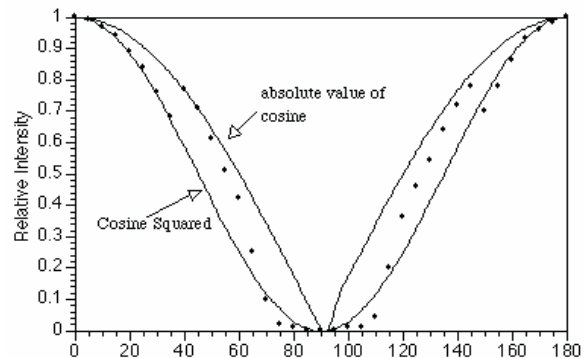

③ The polarizer transmits only the component of the wave parallel to the polarizer.

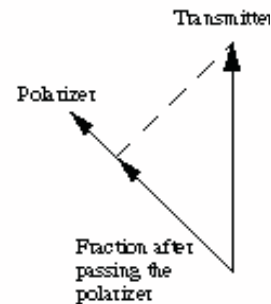

④ When the transmitter and polarizer are at 90°, the wave is completely blocked. Placing a polarizer at 45°, however, introduces a component of the wave parallel to the receiver so that some of the wave is then picked up.

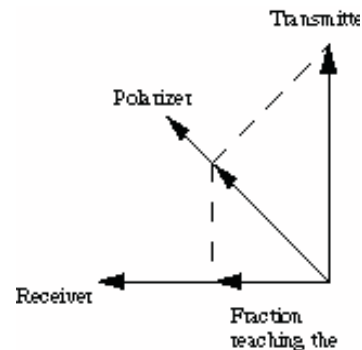

Exp 6– Double-Slit Interference

Answers – to Questions

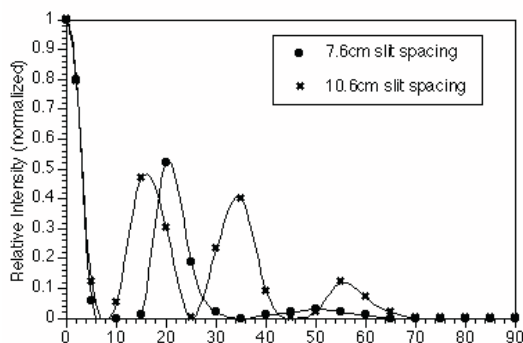

①/② For the 7.6 cm spacing, the maxima should occur at 22° and 48° .

For the 10.6 cm spacing, the maxima should be at 15° , 33° , and 54° .

These theoretical values are closely matched by the experimental data. The theory assumes that the distance between slit plates and receiver are large compared to the slit spacing and wavelength. This requirement is barely met in the experimental setup used, and could cause trouble in some situations.

③ The single-slit pattern (see experiment 7) acts as an upper limit to the multiple-slit pattern from this experiment.

General Notes

- ① The position of the experimenter has a definite effect on the measurements in this experiment. Experiment to find just how much effect there is with your particular setup, and then take your data accordingly.
- ② Single-slit diffraction may also be attempted on this apparatus, though we don't recommend it. The distances are too short, relative to the wavelength; so the analysis requires the Fresnel/Kirchoff approach instead of the Fraunhofer approximation. Even with the Fresnel approach, the "fringes" are too small to be seen adequately.

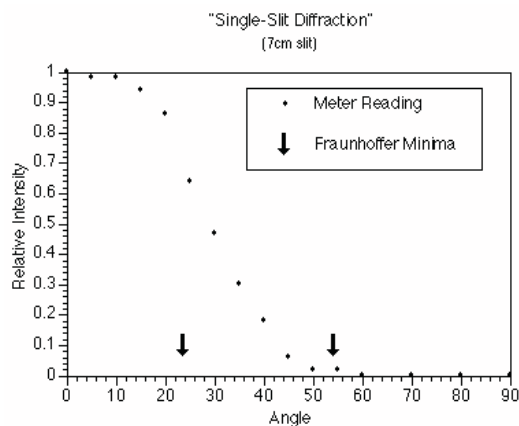

Basically, it doesn't work well at all.

Exp 7– Lloyd’s Mirror

Notes – on Procedure

③-⑧

Fringe#	h (mm)	path length (mm)	lambda
1	85	720	
2	138	752	32.10
3	171	779	26.63
4	200	806	27.15
5	227	834	28.11
6	251	861	27.06
7	275	890	28.83
8	298	919	29.13
9	317	944	25.08
10	338	973	28.69

average: 27.59

stdev: 1.37

An alternate method is to graph path length versus fringe number and take the slope of the graph. This slope will be the wavelength.

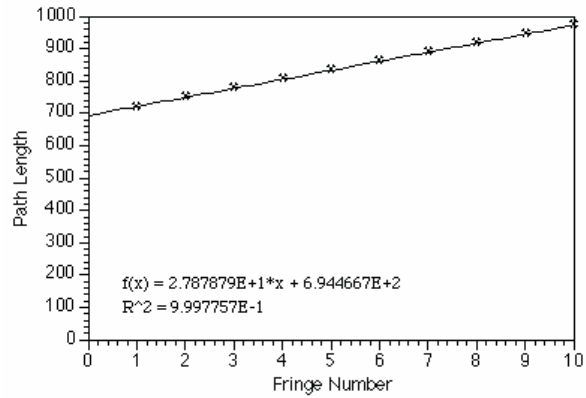

From this, $\lambda = 2.79$ cm.

Answers – to Questions

- ① It simplifies the calculations.

Exp 8– Fabry-Perot Interferometer

Notes – on Procedure

①-④ For best results, do not move the reflector closest to the transmitter. There are actually two standing wave patterns that may form: one between the transmitter and first reflector, and one between the two reflectors. (There may also be others, such as between the second reflector and the receiver or the second reflector and the transmitter; but these will be negligible.) Moving the first reflector will change the amplitude of the wave coming into the region between the reflectors, and thus give erroneous results.

First Plate: 75.2

<u>n</u>	<u>second plate</u>	<u>distance</u>	<u>D</u>
1	54.9	20.3	
2	53.6	21.6	1.3
3	52.2	23.0	1.4
4	50.9	24.3	1.3
5	49.4	25.8	1.5
6	47.9	27.3	1.5
7	46.5	28.7	1.4
8	45.0	30.2	1.5
9	43.6	31.6	1.4
10	42.1	33.1	1.5
11	40.8	34.4	1.3
12	39.4	35.8	1.4
13	38.0	37.2	1.4
14	36.6	38.6	1.4
15	35.1	40.1	1.5
16	33.8	41.4	1.3
17	32.3	42.9	1.5
18	30.9	44.3	1.4
19	29.4	45.8	1.5
20	27.9	47.3	1.5
21	26.5	48.7	1.4
22	25.0	50.2	1.5
	average:		1.42

$$\textcircled{5}/\textcircled{6} = 2.85 \text{ cm}$$

% NOTE: An alternate method of analysis is to make a graph of distance versus fringe number and take the slope of the line to find the wavelength.

$$\lambda = 2.84 \text{ cm}$$

Answers – to Questions

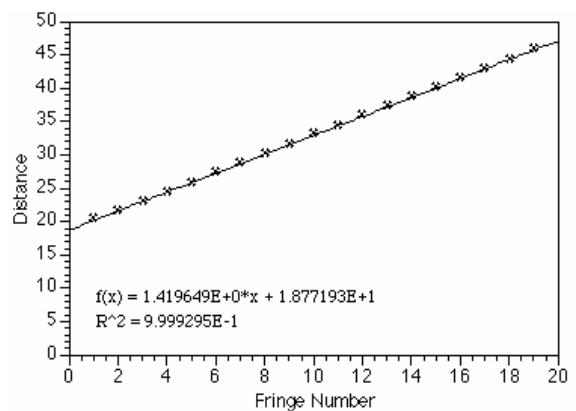

- ① Minima will occur when the spacing is $n\lambda/4$, where n is an odd integer.
- ② We would normally expect just such a pattern; in this case, however, the reflectors are too small in relation to the wavelength used; so the next “ring” is located beyond the edge of the reflectors and may not be seen.

Exp 9– Michelson Interferometer

Notes – on Procedure

①-④ Best results are obtained when the mirrors are both a significant distance from the central beamsplitter. If either mirror is too close to the center, the maxima splits into two peaks due to secondary interference effects.

n	Refl. Pos.	
1	75.0	—
2	76.4	1.4
3	77.9	1.5
4	79.4	1.5
5	80.8	1.4
6	82.2	1.4
7	83.7	1.5
8	85.1	1.4
9	86.6	1.5
10	88.0	1.4
11	89.4	1.4
12	90.9	1.5
13	92.3	1.4
14	93.8	1.5
15	95.2	1.4
16	96.6	1.4
17	98.1	1.5
18	99.5	1.4
19	101.0	1.5
20	102.4	1.4
21	104.0	1.6
	average:	1.45

From this we can calculate the wavelength as being 2.90 cm.

► **NOTE:** An alternate method of analysis is to plot the reflector position versus fringe number. The slope of this line will be half the wavelength.

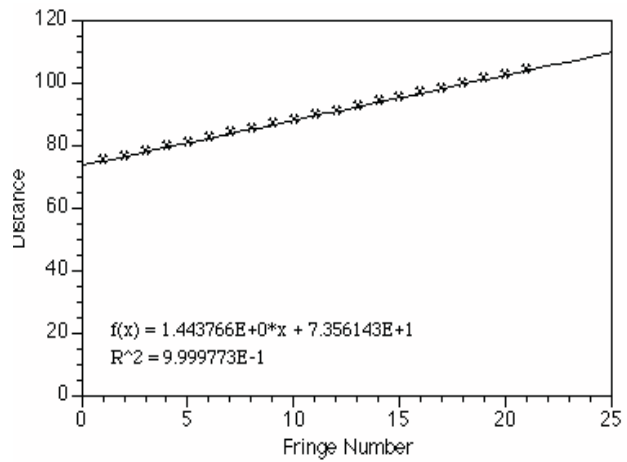

By this method, we calculate the wavelength as 2.89 cm.

Answers – to Questions

- ① The limit of resolution for distance measurements with a Michelson interferometer is roughly 1/4 the wavelength of the light used. Thus with these microwaves, we can measure distance changes of about 7 mm. With a visible-light interferometer and a wavelength of 633 nm (HeNe laser light) we can measure distance changes of only 158 nm.

Exp 10 – Fiber Optics

Notes – on Procedure

- ② The meter reading with the “optical fiber” bag in place can more than double the unobstructed meter reading. This is because the bag prevents the normal spreading of the beam, and directs all the microwave radiation into the receiver horn.
- ③ The bag can direct the beam through a full 90° turn without measurable attenuation, if the curvature is gradual.
- ④ The signal begins to be attenuated with a radius of curvature of about 5 cm, and drops off rather suddenly from there. It is difficult to get consistent results, though.

Answers – to Questions

- ① Theoretically one can use the radius at which the microwaves begin to “leak” to determine the index of refraction of the material. In reality, this is quite difficult. Our values for n using this method range from 1.1 to 1.4.

- ② The styrene pellets are very small, compared to the microwave wavelength. Compared to visible wavelengths, the pellets are enormous. Because of this size difference, optical radiation is scattered by the pellets and microwave radiation is transmitted.

Additional Idea

This apparatus may also be used as a demonstration of how the plane of polarization can be rotated by multiple reflections. Rotate the transmitter or receiver 90° to each other, so that no signal gets through. Now put the bag of pellets between the two. If the bag is held straight, there will be a zero meter reading; but if the bag is curved into a spiral, there will be a non-zero reading.

Exp 11 – Brewster's Angle

Notes – on Procedure

①-⑤

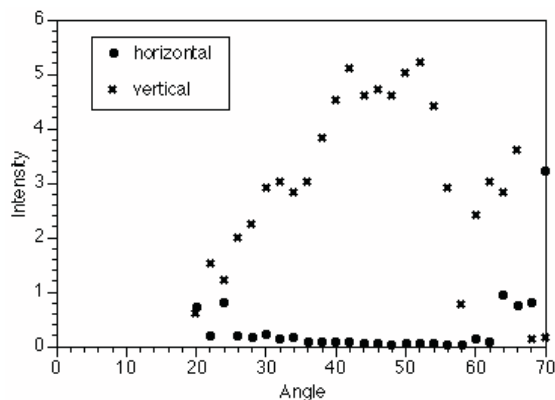

Answers – to Questions

- ① Glare off water from a low source is primarily horizontal in polarization, so sunglasses should be designed to block horizontally polarized light.

- ② Theoretically, one could do this by finding the point at which there was no transmission of vertically polarized light. We have not been able to get good results in this experiment, however.

General Notes

- ① The index of refraction of the polyethylene is 1.5. (Calculated from the dielectric constant at 10 GHz)
- ② One must be careful on this experiment to note that there are actually two effects which are being measured. In addition to the Brewster's angle reflection, there is a certain amount of interference between the front- and rear-surface reflections from the polyethylene. This interference causes extra peaks at 13.8° and 67.2°, and a local minimum at 43.6°. The interference is notable enough that you may want to demonstrate that, instead of the Brewster's angle.

Exp 12– Bragg Diffraction

Notes – on Procedure

- ① The polarization angle of the transmitter and receiver (horizontal or vertical) does not matter.
- ⑤

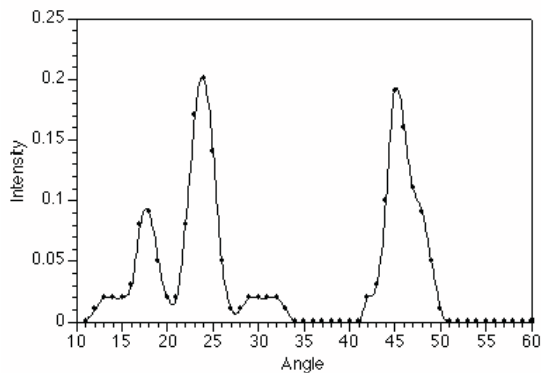
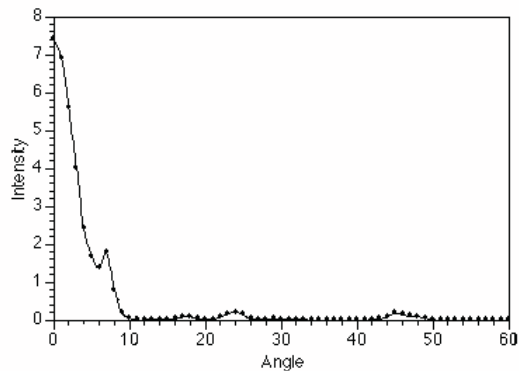

Peaks occur at 18° , 24° , and 45° . These correspond to plane spacings of 4.6cm, 3.4cm, and 4.0 cm ($n = 2$ for the 45° peak) The actual spacing is 3.8 cm The first peak is apparently a reflection off a different plane than the one we're measuring.

- ⑥ 110 Plane:

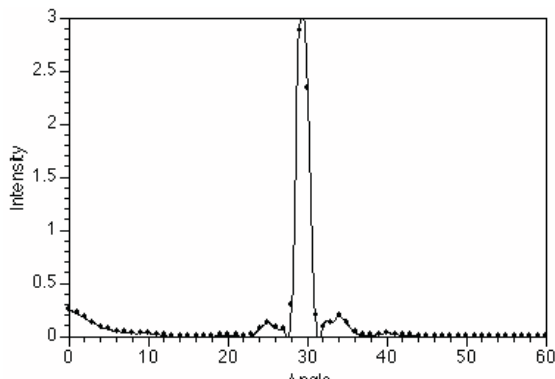

The peak at 29° gives a plane spacing of 2.9 cm; the actual spacing is 2.7 cm

Answers – to Questions

- ① Other families of planes would be the 111 plane, the 101 plane, and so on. These would be difficult to observe with this apparatus due to the small size of our "crystal".
- ② Not knowing the orientation of the interatomic planes of the crystal would increase the complexity of the analysis. We could orient the crystal so that there was maximum transmission; this would indicate to us a 100 plane. From there, we could try different angles until we had enough data to assemble a likely picture of the atomic spacing in the crystal.

► **NOTE:** 10-15% error is reasonable for this experiment.

Appendix

► **NOTE:** Abnormal behavior (weak or erratic meter readings, etc.) may be caused by weak batteries. Please make sure your batteries are good before giving us a call.

► **CAUTION:** The electronics of the Transmitter and Receiver assemblies contain diodes that are not easily repairable. An attempt to repair diode assemblies may void your warranty.

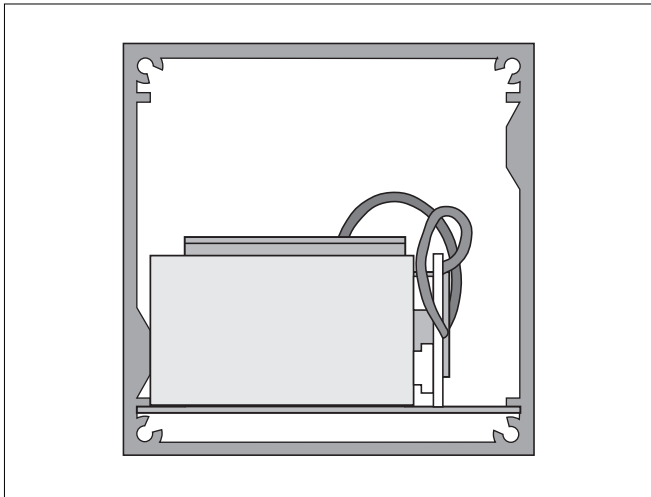

Replacing the Receiver Battery

Replacing the Receiver Battery

The Receiver is powered by two 9-volt alkaline batteries. To replace them, simply remove the back panel of the Receiver (the panel with the rotational scale) by removing the four screws. Install the new batteries, place them into the holder as shown below, and replace the panel.

► **NOTE:** We highly recommend that you use only alkaline batteries.

Adjusting the Receiver

- ① Meter mechanical zero adjustment:
 - a. Turn the INTENSITY control to OFF.
 - b. The mechanical zero adjustment is located on the meter, centered just below the meter face. With the meter level and in the horizontal position, use a small (1/8") flat-blade screwdriver to adjust the meter needle to read as close to 0 as possible.
- ② Electronic offset null adjustment:
 - a. Make sure the Transmitter is OFF by unplugging it.
 - b. Turn the INTENSITY control to the 1X position.
 - c. Turn the VARIABLE SENSITIVITY control all the way clockwise to its maximum setting.
 - d. The offset null adjustment is located through a small hole just above the receiver antenna. Use a small (1/8") flat-blade screwdriver to adjust the meter reading as close as possible to 0.

Schematic Diagrams

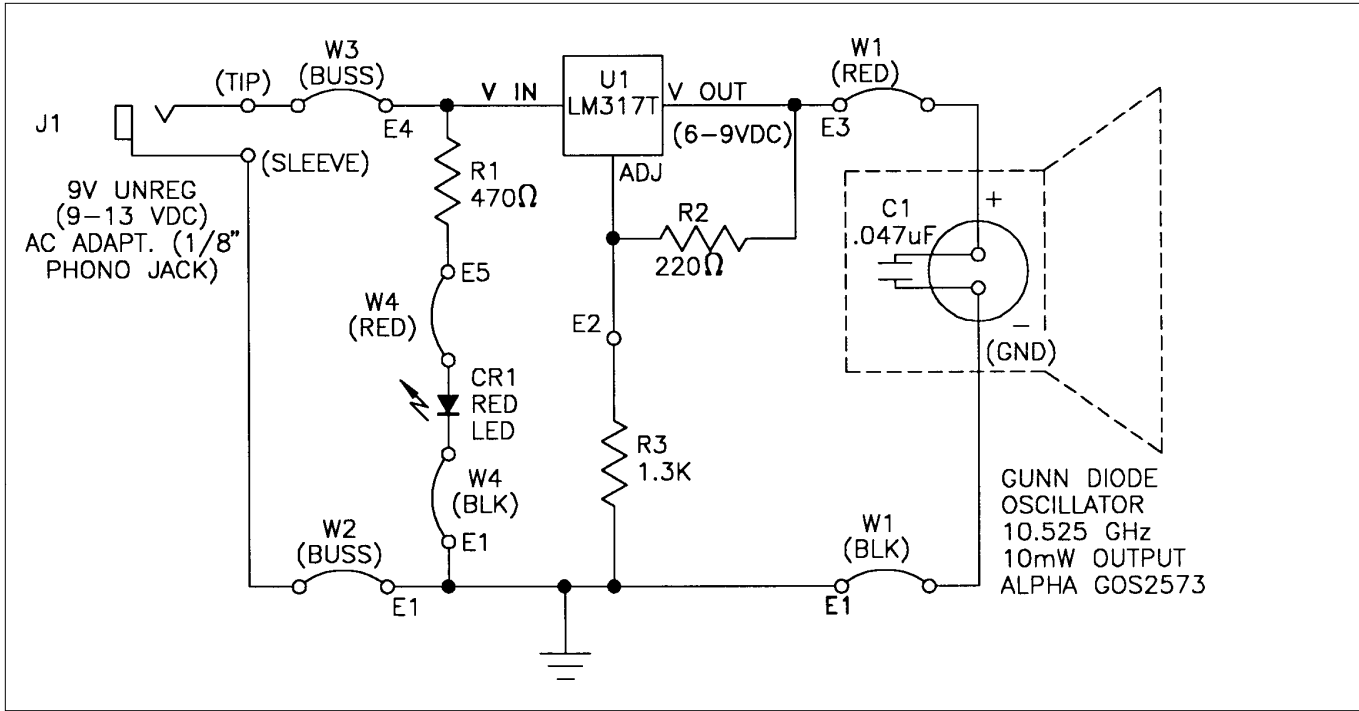

Schematic Diagram, Microwave Transmitter

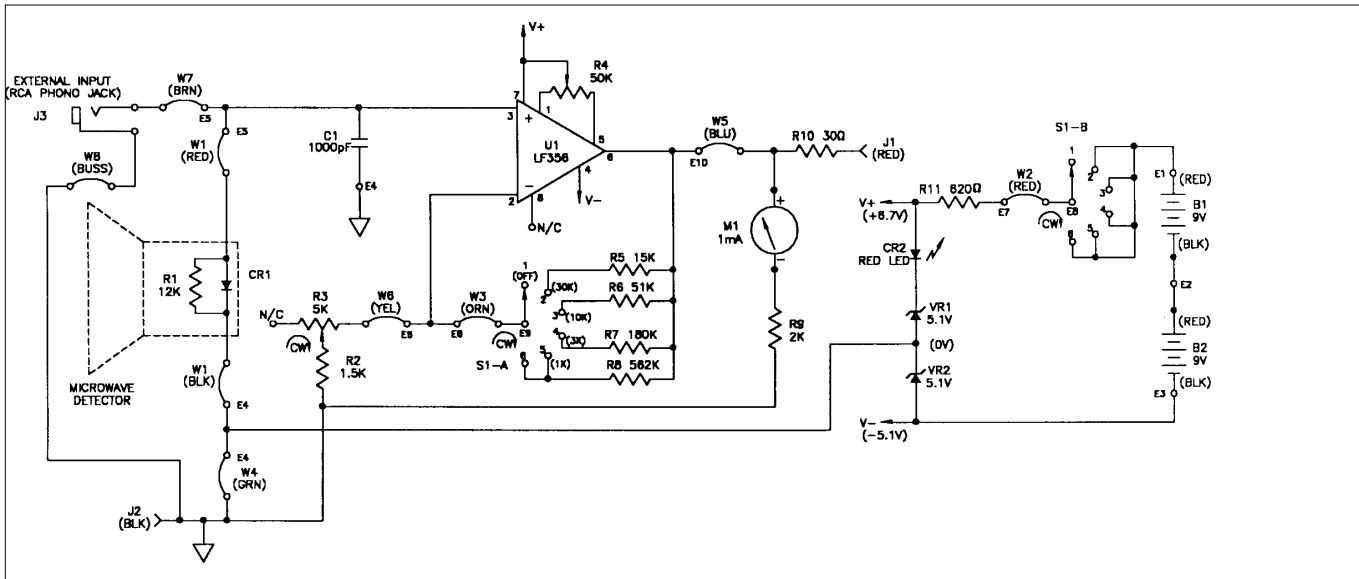

Schematic Diagram, Microwave Receiver

Replacement Parts List

<u>Pasco Part No.</u>	<u>Description</u>	<u>Oty.</u>	
	Transmitter		
003-04319	Transmitter Assembly	1	
113-132	Resistor, 1.3K, 1/4W, 5%	1	
113-221	Resistor, 220 OHM, 1/4W 5%	1	
113-471	Resistor, 470 OHM, 1/4W, 5%	1	
430-085	IC-LM317T Positive V Reg.	1	
445-005	Module, Microwave Transmitter	1	
956-04311	Schematic, Microwave Transmitter	0	
	Receiver		
003-04313	Receiver Assembly	1	
004-04312	Receiver P.C.B. Assembly	1	
113-153	Resistor, 15K, 1/4W, 5%	1	
113-184	Resistor, 180K, 1/4W, 5%	1	
113-621	Resistor, 620 OHM 1/4W 5%	1	
123-013	Resistor, 562K 1/4w 1% MF	1	
123-016	Resistor, 51.1K 1/4w 1% MF	1	
142-028	Trimpot, 50K 1T .5W CERM SA	1	
216-026	Capacitor, 1000pF 5% 25V	1	
412-012	Zener Diode, 1N751A 5.1V 5% .4W	2	
430-086	IC-LF356N FET OP-AMP DIP	1	
510-019	Switch, Rotary, 2POLE 6POS	1	
527-001	L.E.D, Red	1	
555-02811	Printed Circuit Board	1	
113-152	Resistor, 1.5K, 1/4W, 5%	1	
113-300	Resistor, 30 OHM, 1/4W, 5%	1	
123-2001	Resistor, 2K 1/4W 1% MF	1	
140-01716	Modified Pot - 5K	1	
140-040	Pot, 5K	1	
445-006	Module, Microwave Receiver	1	
525-008	Meter	1	
710-04313	Wire List, Microwave Receiver	0	
956-04312	Schematic, Microwave Receiver	0	
	Components		
003-01748	Assembly, Partial Reflector	2	
003-02090	Assembly, Receiver/Transmitter Stand	2	
003-02091	Assembly, Component Holder	2	
003-02092	Assembly, Rotating Component Holder	1	
003-02093	Assembly, Fixed Arm	1	
003-02094	Assembly, Goniometer	1	
003-02100	Assembly, Rotating Table	1	
003-02116	Assembly, Styrene Pellets	1	
003-02817	Assembly, Slit Extender Arm	1	
540-002	Battery, 9 Volt, Alkaline	2	
540-007	AC Adapter, 120VAC, 9VDC	1	
or	540-013	AC Adapter, 220/240VAC, 9VDC	1
	648-01749	Metal Reflector	2
	648-02042	Slit Spacer, Narrow	1
	648-02043	Slit Spacer, Wide	1
	648-02052	Polarizer Screen	2
	648-02082	Ethafoam Prism	1
	735-027	Plastic Bag, 2 1/2" X 24"	4

► **NOTE:** Replacement parts can be purchased from PASCO or at most electronic stores.

Notes

Technical Support

Feedback

If you have any comments about the product or manual, please let us know. If you have any suggestions on alternate experiments or find a problem in the manual, please tell us. PASCO appreciates any customer feedback. Your input helps us evaluate and improve our product.

To Reach PASCO

For technical support, call us at 1-800-772-8700 (toll-free within the U.S.) or (916) 786-3800.

fax: (916) 786-3292

e-mail: techsupp@pasco.com

web: www.pasco.com

Contacting Technical Support

Before you call the PASCO Technical Support staff, it would be helpful to prepare the following information:

- If your problem is with the PASCO apparatus, note:
 - Title and model number (usually listed on the label);
 - Approximate age of apparatus;
 - A detailed description of the problem/sequence of events (in case you can't call PASCO right away, you won't lose valuable data);
 - If possible, have the apparatus within reach when calling to facilitate description of individual parts.
- If your problem relates to the instruction manual, note:
 - Part number and revision (listed by month and year on the front cover);
 - Have the manual at hand to discuss your questions.

