

PHOTOGATE MOUNTING BRACKET

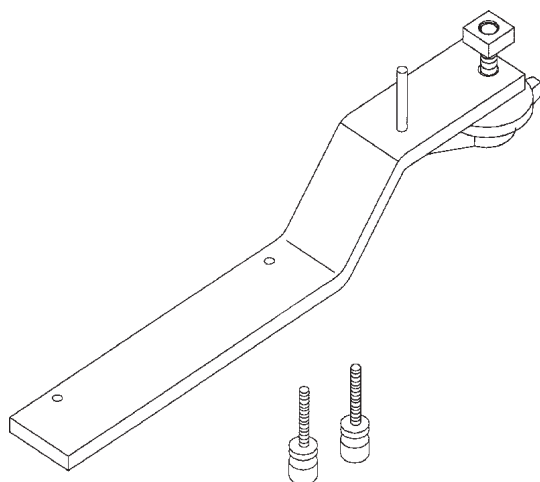

Introduction

The PASCO Model ME-6821 Photogate Mounting Bracket is designed for use as an accessory to the PASCO Projectile Launcher. It attaches to the front of the launcher and holds one or two photogates in parallel.

Additional Equipment Required:

- Projectile Launcher (ME-6800, ME-6801 or ME-6823)
- (2) Photogate Heads (ME-9498A)

Additional Equipment Recommended:

- Shoot-the-Target Accessory (ME-6805)
- Time-of-Flight Accessory (ME-6810)

Experiments

Please refer to the experiment guide that comes with the applicable PASCO equipment for specific experiments.

Setup procedure

- Loosen the thumbscrew of the Photogate Mounting Bracket.

- Align the bracket assembly with the front of the Projectile Launcher and slide the square nut down the groove of the barrel until the dowel pin enters the groove.

(The dowel pin acts as an alignment guide and must enter the groove for proper alignment of the bracket.)

► **NOTE:** The flat side of the square nut must face the inside of the projectile launcher groove as shown.

- Slide the Photogate Mounting Bracket to the desired position and tighten the thumbscrew to secure.
- Unscrew the small rod clamp from the Photogate Head. (Save the clamp and its 6-32 x 5/8" thumbscrew for later use.)
- Attach each Photogate Head to the Mounting Bracket with one of the 6-32 x 3/8" nylon thumbscrews included with the bracket assembly. (Do not use the longer 6-32 x 5/8" thumbscrew from the photogate's rod clamp.)

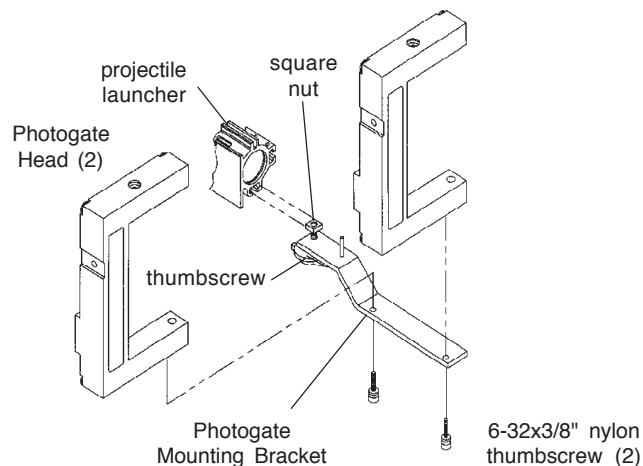

© 1992 PASCO scientific

This instruction sheet edited by: Martina Graham

Technical Support

Feedback

If you have any comments about the product or manual, please let us know. If you have any suggestions on alternate experiments or find a problem in the manual, please tell us. PASCO appreciates any customer feedback. Your input helps us evaluate and improve our product.

To Reach PASCO

For technical support, call us at 1-800-772-8700 (toll-free within the U.S.) or (916) 786-3800.

fax: (916) 786-3292

e-mail: techsupp@pasco.com

web: www.pasco.com

Contacting Technical Support

Before you call the PASCO Technical Support staff, it would be helpful to prepare the following information:

- ▶ If your problem is with the PASCO apparatus, note:
 - Title and model number (usually listed on the label);
 - Approximate age of apparatus;
 - A detailed description of the problem/sequence of events (in case you can't call PASCO right away, you won't lose valuable data);
 - If possible, have the apparatus within reach when calling to facilitate description of individual parts.
- ▶ If your problem relates to the instruction manual, note:
 - Part number and revision (listed by month and year on the front cover);
 - Have the manual at hand to discuss your questions.