

**Instruction Sheet
for the PASCO
Model ME-9448**

Super Pulley with Clamp

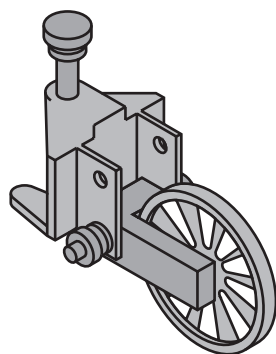

Introduction

The PASCO Model, ME-9448 Super Pulley with Clamp is designed to be used wherever an integral clamp that features the low friction characteristics of our Super Pulley is needed.

Specifications

Fully adjustable pulley height.

Fits tables up to $\frac{3}{4}$ " thick.

Pulley:

Diameter = 5.1cm (2")

Outside circumference = 16cm (6.3")

Groove circumference = 15cm (5.9")

Mass = 5g

Moment of inertia approx. $18.6 \times 10^{-7} \text{kgm}^2$

Helpful Hints

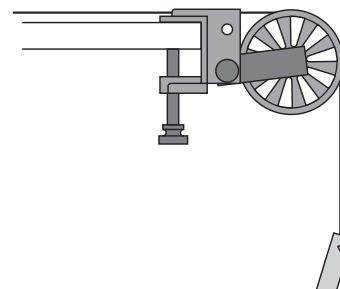

Figure 1

When using the Super Pulley with Clamp on a force table keep strings as close and parallel to the surface of the table as possible. See Figure 1.

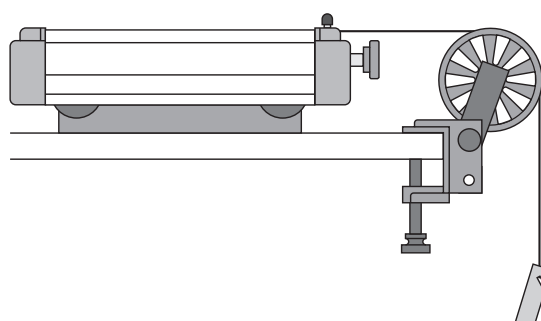

Figure 2

Strings should also remain parallel when using the Super Pulley with Clamp on incline planes or any table that might be used for demonstration. See Figure 2.

© 1992 PASCO scientific

Limited Warranty

PASCO scientific warrants this product to be free from defects in materials and workmanship for a period of one year from the date of shipment to the customer. PASCO will repair or replace, at its option, any part of the product which is deemed to be defective in material or workmanship. This warranty does not cover damage to the product caused by abuse or improper use. Determination of whether a product failure is the result of a manufacturing defect or improper use by the customer shall be made

solely by PASCO scientific. Responsibility for the return of equipment for warranty repair belongs to the customer. Equipment must be properly packed to prevent damage and shipped postage or freight prepaid. (Damage caused by improper packing of the equipment for return shipment will not be covered by the warranty.) Shipping costs for returning the equipment, after repair, will be paid by PASCO scientific.