

WA-9896 Ripple Generator and Light Source WA-9899 Ripple Tank System



Contents

| | |
|--|----|
| Introduction | 3 |
| About the Equipment | 5 |
| About the Experiments. | 10 |
| Experiment 1: Reflection | 11 |
| Experiment 2: Refraction | 15 |
| Experiment 3: Diffraction | 19 |
| Experiment 4: Interference. | 21 |
| Experiment 5: Image Formed by a Plane Mirror | 25 |
| Experiment 6: Wave Speed | 27 |
| Doppler Effect Demonstration | 29 |
| Sample Results | 30 |
| Technical Support | 31 |

Ripple Tank System

WA-9899

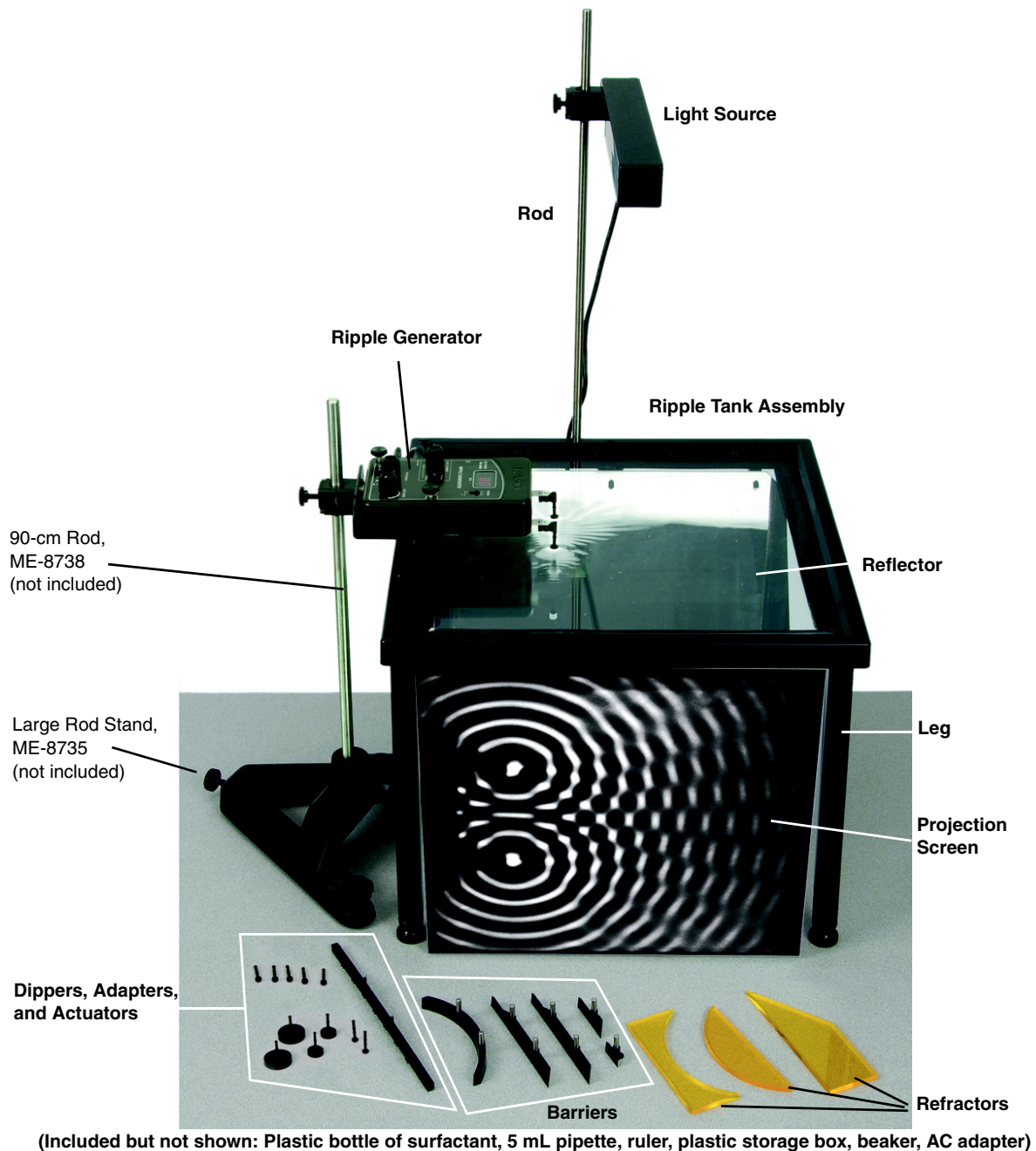

Introduction

The Ripple Tank System consists of the WA-9896 Ripple Tank and the WA-9897 Ripple Generator and Light Source. The table below lists the included equipment. Note: The ME-8735 Large Rod Stand and the ME-8738 90-cm Rod shown above are recommended but not included.

This manual contains descriptions and instructions for six experiments and suggestions for an additional demonstration.

| Included Equipment | WA-9896 | WA-9897 | Part Number |
|---------------------------------------|---------|---------|-------------|
| 1. Light Source | 1 | | 003-09709 |
| 2. Rod | | 1 | 648-09713 |
| 3. Ripple Generator | 1 | | 003-09724 |
| 4. Ripple Tank Assembly | | 1 | 003-09703 |
| 5. Screen Assembly | | 1 | 003-09736 |
| 6. Leg | | 3 | 648-09707 |
| 7. Standard Dipper | 7 | | 648-09712 |
| 8. Large Actuator | 2 | | 648-05471 |
| 9. Small Actuator | 2 | | 648-05470 |
| 10. Dipper Adapter | 2 | | 648-09711 |
| 11. Plane Dipper | 1 | | 003-09737 |
| 12. Curved Reflector | | 1 | 648-09820 |
| 13. Long Diffraction Barrier | | 2 | 648-09718 |
| 14. Short Diffraction Barrier | | 1 | 648-09719 |
| 15. Mini Diffraction Barrier | | 1 | 648-09717 |
| 16. Concave Refractor | | 1 | 648-09720 |
| 17. Convex Refractor | | 1 | 648-09721 |
| 18. Trapezoidal Refractor | | 1 | 648-09714 |
| 19. Bottle of surfactant ¹ | | 1 | 650-072 |
| 20. Pipette, 5 mL | | 1 | 699-154 |
| 21. Ruler | | 1 | 699-081 |
| 22. Plastic Storage Box | | 1 | 740-177 |
| 23. Beaker, 1000 mL | | 1 | 699-197 |
| 24. AC Adapter, 15 VDC, 1.6 A | 1 | | 540-057 |

¹ Note: The Tergitol L-62 surfactant is part number 699-023

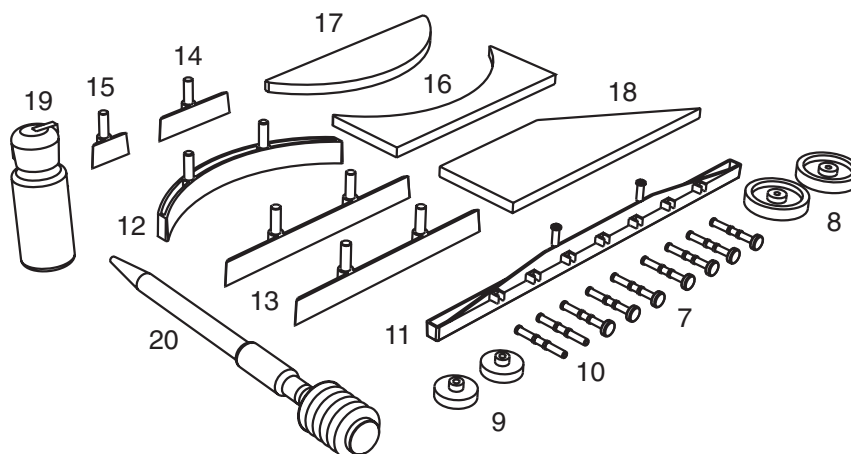

About the Equipment

WA-9897 Ripple Tank

The Ripple Tank is designed to be used with the PASCO model WA-9896 Ripple Generator and Light Source. The tank is 42.5 cm by 42.5 cm by 2.5 cm with four foam “beaches” and a 0.3 cm thick glass plate. The viewing area is 33 cm by 33 cm. The tank has an easy-to-use drain pipe consisting of a piece of flexible vinyl plastic tubing and a tube clamp. The tank is supported by three detachable legs with adjustable feet and comes with a reflector and projection screen.

The ripple tank also comes with the following: ruler, pipette, surfactant bottle, storage box, barriers (5 pieces), refractors (3 pieces), a beaker, and a rod for supporting the light source.

The box in which the Ripple Tank is stored has two layers. The screen assembly, plastic storage box, rod, and beaker are in the top layer; the ruler, legs, and Ripple Tank assembly are in the bottom layer. The top layer has areas for storing the WA-9896 Ripple Generator and Light Source, including the power adapter and cord.

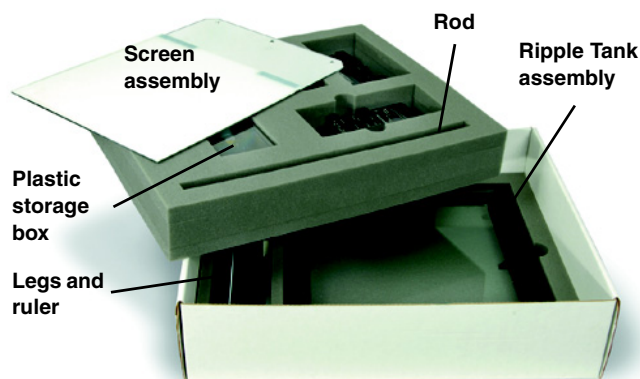

Screen Assembly The screen assembly is a reflector and a projection screen joined at one edge by a strip of flexible tape. Note: Remove any protective coating from the reflector and the screen before using. The reflector is aluminized acrylic. The projection screen is translucent plastic.

There are three holes along the top edge of the reflector and two strips of Velcro® ‘loop’ material along the top edge of the projection screen.

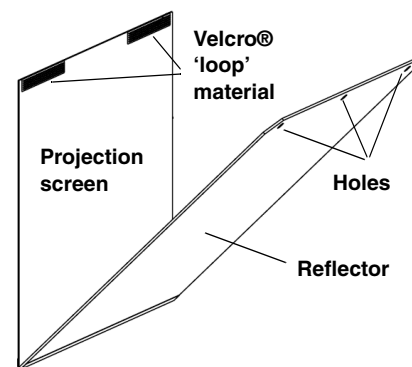

Ripple Tank Assembly The ripple tank assembly has an impact resistant plastic frame. Below the front edge of the frame is a strip of Velcro® ‘hook’ material that will hold the ‘loop’ material on the top edge of the projector screen. Below the back edge of the frame are three pegs that fit into the holes in the top edge of the reflector. The threaded hole on the top side of the back edge is for the rod that can support the Light Source that is included in the WA-9896 Ripple Generator and Light Source. When the ripple tank is in use, the four foam ‘beaches’ dampen the waves that would otherwise reflect and disturb the primary wave and interference patterns. The foam beaches are replaceable. (A variety of replacement parts are available in the WA-9898 Ripple Tank Replacement Set.)

The ripple tank’s drain pipe is a piece of flexible vinyl tubing attached below the drain hole at the back corner of the tank. Squeeze the sides of the tube clamp on the drain pipe to tighten the clamp on the tubing. Pull downward on the lip of the tube clamp to loosen the clamp.

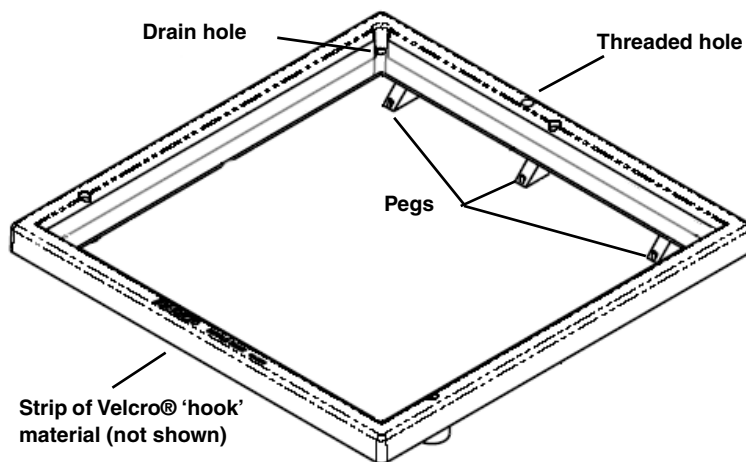

Setup

To setup the ripple tank, screw the legs into the threaded holes on the underside near the two front corners of the tank, and under the midpoint of the back edge. Place the ripple

tank on a smooth, level surface. If you are going to use the light source, screw the rod into the threaded hole near the midpoint of the top of the back edge.

To attach the reflector and projection screen to the tank, unfold the screen assembly and put the reflector between the two front legs. Angle the reflector upwards and guide the top edge so that the three holes fit over the pegs that are at the back edge of the tank. Next, raise the projection screen to the vertical position and attach its Velcro® 'loop' material to the strip of 'hook' material under the front edge of the tank.

Apply Surfactant Before putting water into the ripple tank for the first time, prepare the foam beaches, barriers, and refractors with a drop of surfactant (a nonionic wetting agent). The surfactant helps to avoid problems with the surface tension of the water. Put a single drop of surfactant from the small plastic bottle onto the end of one finger, and lightly rub your finger along the foam beaches. Use a single drop of surfactant to very sparingly coat the large flat surfaces of the three refractors and the front surfaces of the straight and curved barriers.

Tip: Note that you only need to apply the surfactant to the beaches, barriers, and refractors before using the ripple tank for the first time, or it has been unused for a long time.

Level the Ripple Tank When you are ready to add water to the tank, squeeze the sides of the tube clamp to close the clamp. Use the beaker to add a small amount of water to the middle of the tank so that the water forms a circle about 10 cm in diameter. Adjust the feet on the legs until the circle of water stays in the middle of the tank and does not move toward any side. (An alternate method for leveling the tank is to add about 800 milliliters of water to the tank. Measure the water depth at three of the four corners of the tank and adjust the feet on the legs until the depths are the same.)

Dampen the Foam Beaches To reduce the problem of surface tension, let the foam beaches soak up some of the water. After putting about 800 milliliters of water in the tank, press down on the foam and then release the pressure so that water enters the pores of the foam rubber.

Cleanup

Before emptying the tank, remove the projection screen and reflector. Fold the screen assembly so the projection screen protects the reflector.

To empty the tank, place a container under the drain pipe and open the tube clamp. When the water stops flowing, raise the corner of the tank opposite to the drain hole so the rest of the water will drain out. Leave the tube clamp in the open position.

Be careful to remove as much water from the foam beaches as possible. Press with your thumbs against the foam to squeeze the water out. Next, press a rolled-up towel onto the foam beaches to soak up any remaining water.

Tip: Leave the tube clamp in the open position after draining the tank to avoid crimping the plastic tubing.

Completely dry the glass plate so that water spots won't form on it. To clean the glass plate or the reflector, use a soft cloth moistened with water and then dry with a clean towel. Do not use soap or chemical cleaners.

WA-9896 Ripple Generator and Light Source

The Ripple Generator is designed to be used with the WA-9897 Ripple Tank. The generator controls the included Light Source. The Light Source uses a white light-emitting diode (LED) that remains cool during operation and produces a bright, clear image of the wave patterns in the ripple tank. The light can be used as a steady source or as a strobe to 'freeze' the motion of the wave patterns. The ripple generator frequency range is from 1.0 to 50 Hz adjustable in 0.1 Hz increments, and the generator has a digital frequency readout window that is easy to see in dim light. The generator uses voice coil actuators to produce the precise and quiet up-and-down motion of the rippler arms. The ripple generator has knobs for adjusting the dipper depth and amplitude and a switch for changing the phase of the two rippler arms from zero (in phase) to 180 degrees (out of phase).



WA-9896 Ripple Generator (right) and Light Source (left) with power adapter and cord

Generator Attachments The ripple generator includes a plane wave dipper (1), small actuators (2), dipper adapters (3), standard dippers (4), and large actuators (5). The plane wave dipper and the standard dippers attach to the clips at the end of each rippler arm. Use the dipper adapters to attach the small or large actuators to the rippler arms, or to the clips on one side of the plane wave dipper. The standard dippers can be attached to the clips at the end of each rippler arm or to the clips on the plane wave dipper.

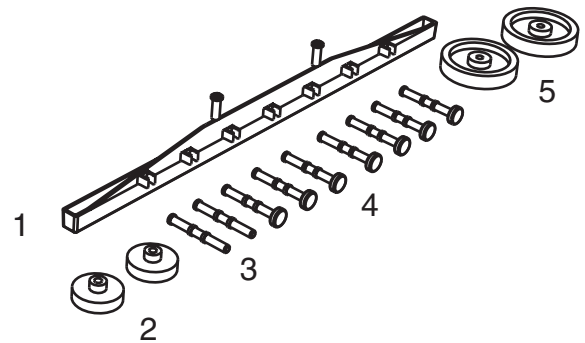

Generator Attachments

The standard dippers and dipper adapters are designed so that the top 'third' of the part fits securely into the clips on the rippler arms. The parts fit into the clips in one way; do not force them into the clips. The dippers and adapters are designed so that the 'middle third' of the part fits into the clips on the plane wave dipper.

The standard dippers and dipper adapters can be used as 'point sources' when attached to the ripple generator. In general, the higher the frequency of the ripple generator, the smaller the point source attachment should be in order to produce the sharpest looking circular waves.

Mounting the Light Source The light source has a built-in rod clamp for mounting the light on the rod that comes with the ripple tank assembly. Mount the light source near the top of the rod so that the light source is at right angles to the rod and the opening of the light source is above the center of the ripple tank.

Mounting the Ripple Generator Use the built-in rod clamp on the end of the ripple generator to mount the generator on a 90-cm rod (ME-8738, not included) that is supported by a large rod base (ME-8735, not included). Position the ripple generator so that it is slightly above the midpoint of one side of the ripple tank but does not touch the tank. Arrange the generator so that it is at right angles to the side of the ripple tank, and the midpoint of the generator is approximately in line with the inner edge of the ripple tank.

Connecting the Power Adapter The ripple generator comes with an AC adapter that provides 15 V DC (at up to 1.6 A). Connect the included power cord between an electrical outlet and the AC adapter, and then connect the plug from the adapter into the power input port on the side of the ripple generator.

Connecting the Light Source Connect the power cord from the light source into the jack on the side of the ripple generator that is beneath 'TO LIGHT' on the label.

Tip: Before using the plane wave dipper or the other dippers or the actuators for the first time (or after a long period of non-use), lightly coat the bottom surfaces with a very small amount of surfactant.

Tip: Before connecting the power adapter to the ripple generator, be sure that the 'ON-OFF' switch on the left side of the generator is in the 'OFF' position.

Also, turn the 'AMPLITUDE' knob on the top of the generator fully counter-clockwise.

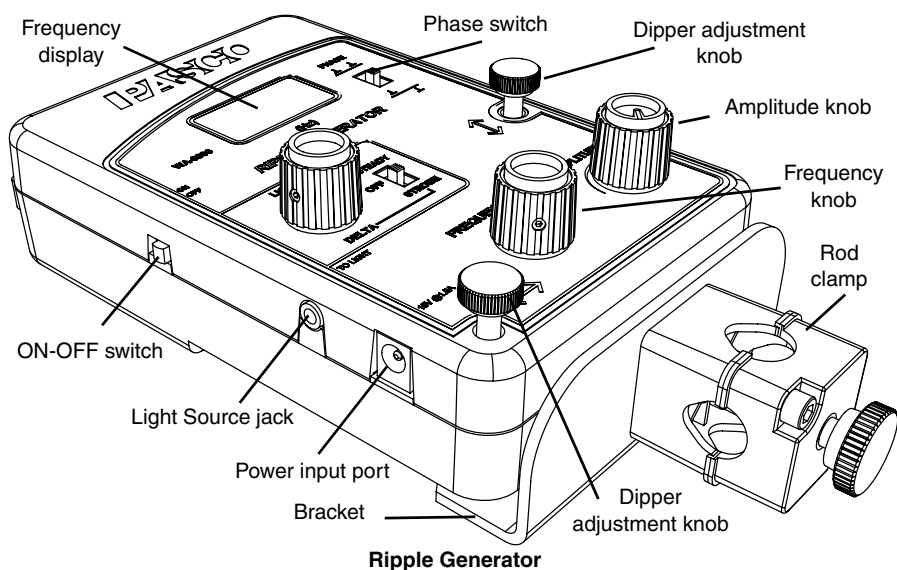

Dipper Adjustment The ripple generator has two dipper adjustment knobs for making small changes to the height and orientation of the generator. You can make fine adjustments with these two knobs to position the dippers, plane wave dipper, or actuators in the water without moving the entire ripple generator up or down on its rod. Use the knob on the right side of the generator to move the front end of the generator up or down. Use the knob at the back corner of the generator to tilt the front end of the generator right or left (clockwise or counter-clockwise).

Before making adjustments, check that the ripple generator is parallel to the bracket when the ripple generator is mounted on the rod. This will allow for the widest range of adjustments when you use the plane wave dipper, standard dippers, or actuators.

It is very important that the dippers barely touch the surface of the water in the tank. For the plane wave dipper, it is also important that the dipper has equal contact with the surface of the water over the entire length of the dipper.

One way to adjust the ripple generator when it is on the rod is to grip the rod below the rod clamp, loosen the thumbscrew of the rod clamp, and support the rod clamp with your thumb. Gradually nudge the rod clamp up or down on the rod until the dippers attached to the rippler arms are in contact with the water, then tighten the thumbscrew of the rod clamp to secure the ripple generator on the rod.

Next, use the two dipper adjustment knobs to raise, lower, or tilt the ripple generator so the dippers barely touch the surface of the water. When everything is adjusted, the water will appear to ‘curve upwards’ on the sides of the dipper.

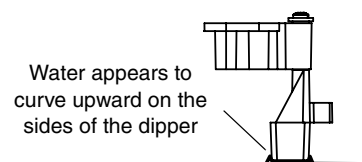
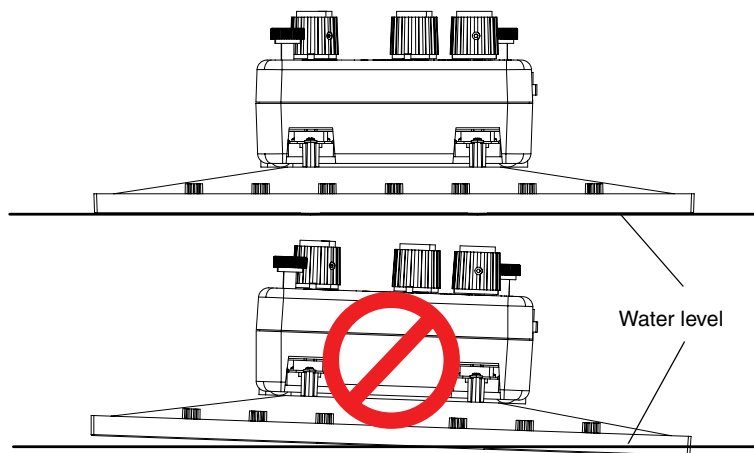
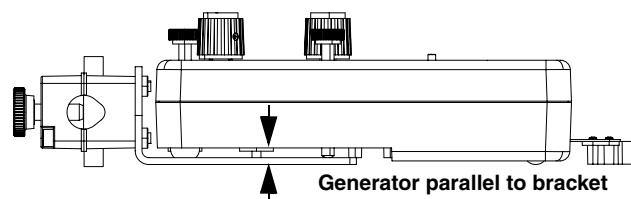

Amplitude Adjustment The Amplitude knob adjusts the ripple arm amplitude. As you turn the knob clockwise, the amplitude increases. Turning the knob counter-clockwise (right-to-left) decreases the amplitude.

As a general rule, adjust the amplitude in all experiments to get a clear wave patten without distortions.

Frequency Adjustment The Frequency knob adjusts the ripple arm frequency. The Frequency display shows the frequency in 0.1 Hz increments. The range is from 1.0 to 50.0 Hz. When the ripple generator is first turned on, the default frequency is 20.0 Hz, a good starting frequency for the experiments described later. Turn the knob clockwise to increase the frequency or counter-clockwise to decrease the frequency.

Phase Switch The Phase switch at the upper right of the ripple generator changes the phase of the two rippler arms from zero degrees ('in phase') to 180 degrees ('out of phase'). The switch can be used while the ripple generator is in operation.

Light Source Control The Light Source can be used as a strobe or as a steady source. The controls for the light source consist of a three-position Mode switch for selecting 'STEADY', 'OFF', and 'STROBE', and a 'DELTA' knob that adjusts the frequency of the light source when it is in the strobe mode.

DELTA Feature Normally the frequency of the light source in the strobe mode is the same as the frequency of the ripple generator. When the frequency of the light source is 5.0 Hz or more, you can use the 'DELTA' knob to increase or decrease the frequency of the light independently of the frequency of the ripple arms. (When the generator frequency is *less* than 5.0 Hz, the 'DELTA' knob will not change the light source frequency.) Turn the 'DELTA' knob clockwise to increase the light source frequency or counter-clockwise (right-to-left) to decrease the frequency. Each 'click' of the 'DELTA' knob changes the frequency of the light source by 0.8 Hz. The Frequency display on the top of the ripple generator will show the 'DELTA' increment (e.g., 1.0, 2.0, 3.0, 4.0, or 5.0 if the 'DELTA' knob is turned clockwise, or -1.0, -2.0, etc., if the knob is turned counter-clockwise) for a few moments and then change back to show the *ripple generator* frequency. For example, if the Frequency display shows '20.0' Hz, and you turn the 'DELTA' knob one 'click' clockwise, the Frequency display shows '1.0' momentarily, and the light source frequency becomes 20.8 Hz. Note that the ripple generator will continue to oscillate at 20.0 Hz.

This feature of the light source allows the wave pattern to 'appear to move' at a constant, predictable speed when the light source is in the strobe mode and the light source frequency is slightly higher or lower than the ripple generator frequency.

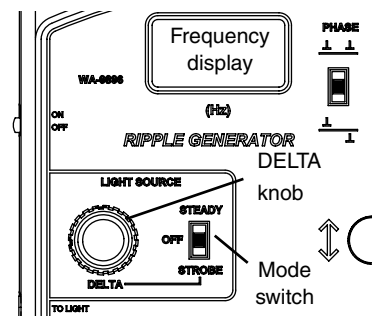

About the Experiments

These experiments can be done with the equipment included in the system and other items such as a protractor, drawing compass, and paper. See each experiment for a specific equipment list.

1. **Reflection:** Study the reflection of plane waves from straight and curved barriers.
2. **Refraction:** Study how plane waves bend when they pass from one medium to another where the wave speed is different.
3. **Diffraction:** Determine how a diffraction pattern of plane waves changes as the slit width of the barriers changes and the wavelength changes.
4. **Interference:** For a double-slit interference pattern, determine how the interference pattern changes as the slit width separation and the wavelength are varied.
5. **Image Formed by a Plane Mirror:** Determine the position of the image formed by a plane mirror relative to the image distance from the mirror.
6. **Wave Speed:** Determine how wave speed depends on frequency and on water depth.
7. **Doppler Effect Demonstration:** Demonstrate the Doppler Effect by moving the ripple generator at a constant speed in a straight line.

Experiment 1: Reflection

Equipment from Ripple Tank System

| | |
|----------------|-----------------------------------|
| Ripple Tank | Ripple Generator and Light Source |
| Long Barrier | Plane Wave Dipper |
| Curved Barrier | Ruler |

Other Equipment and Materials

| | |
|------------------------------|-----------------|
| Large Rod Stand (ME-8735) | Protractor |
| 90-cm Rod (ME-8738) | Drawing compass |
| Paper (about 40 cm by 40 cm) | |

Purpose

The purpose of this activity is to study the reflection of a plane wave from different shaped barriers: a long straight barrier and a curved barrier.

Theory

A ray is a line that indicates the direction of motion of a plane wave. Wave fronts are perpendicular to the ray. When a wave reflects from a surface, the angle of incidence is the angle between the incoming (or incident) ray and the normal (a line perpendicular to the surface). The angle of reflection is the angle between the outgoing (reflected) ray and the normal.

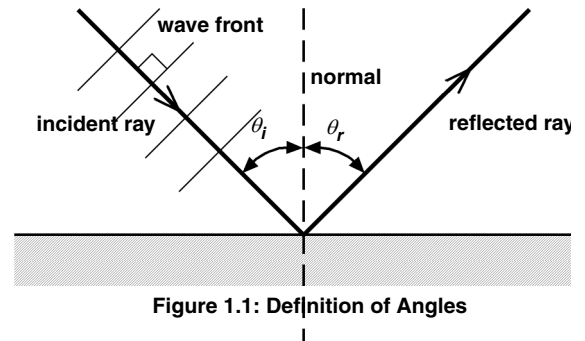

Setup

1. Mount the light source onto its rod at the back edge of the ripple tank.
2. Pour a small amount of water into the tank and adjust the feet on the legs of the tank to level the tank.
3. Place the long straight barrier in the middle of the tank and add about 800 mL of water to the tank (or enough water so that the water level is about halfway up the long straight barrier.)
4. Use a rod and base to support the ripple generator and position the generator over the midpoint of one side of the ripple tank. Plug the light source into the ripple generator and connect the ripple generator to its power adapter.
5. Connect the plane wave dipper to the ripple arms. Adjust the ripple generator until the bottom of the plane wave dipper is barely in contact with the surface of the water.
6. Place a sheet of paper directly under the ripple tank so you will be able to sketch the images of the waves that are projected onto the sheet by the light source.

Tip: Make sure that the plane wave dipper is in contact evenly over its length.

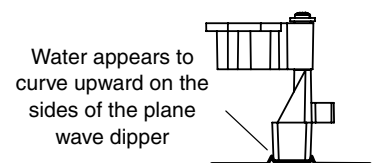

Part 1: Reflection Using a Straight Barrier

Procedure

1. Arrange the long barrier in the middle of the tank so the barrier is at an angle to the plane wave dipper (see Figure 1.2).
2. Turn on the ripple generator and the light source. Set the light source to 'STROBE'. Set the ripple generator frequency to 20 Hz. Set the amplitude to slightly less than half of maximum.
3. On the paper below the tank, place the ruler parallel to the plane waves that are incoming to the barrier. Make a line to show the incoming wave front.
4. Place the ruler parallel with a reflected wave and again make a line to show the outgoing (reflected) wave front.
5. Trace the position of the straight barrier.
6. Turn off the ripple generator and light source.

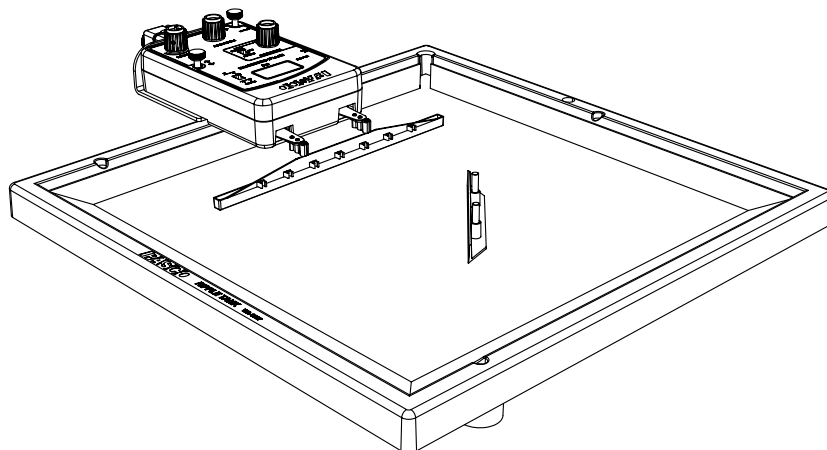

Figure 1.2: Position of Straight Barrier

Tip: Adjust the amplitude as necessary to make a clear pattern of plane waves.

Data Analysis

1. Draw a line that is perpendicular to the incoming wave front and extend the line to the outline of the straight barrier. This represents the incoming ray, so draw an arrow on it pointing to the barrier.
2. Draw a line from the point where the incoming ray intersects the straight barrier so it crosses the reflected wave front at a right angle. This represents the reflected ray, so draw an arrow on it pointing away from the barrier.
3. Draw the normal (perpendicular) line at the point of reflection on the outline of the straight barrier.
4. Measure the angle of incidence and the angle of reflection and record the measurements in the table.
5. Repeat the procedure with the barrier at a different angle.

Table 1.1: Reflection Results

| | Trial #1 | Trial #2 |
|---------------------|----------|----------|
| Angle of Incidence | | |
| Angle of Reflection | | |

Question

1. What is the relationship of the angle of incidence and the angle of reflection?

Part 2: Reflection Using a Curved Barrier

Procedure

1. Replace the straight barrier with the curved barrier and position the curved barrier so it is aligned 'parallel' to the plane wave dipper as shown in Figure 1.3.
2. Turn on the light source. Trace the position of the curved barrier on the paper below the ripple tank.
3. Turn on the ripple generator.
4. Mark the position on the paper where the waves that reflect from the curved barrier appear to converge. Turn off the ripple generator.
5. Use the pipette to drop a single droplet of water at the position in the ripple tank where the waves converged. Describe the shape of the waves that reflect from the curved barrier.

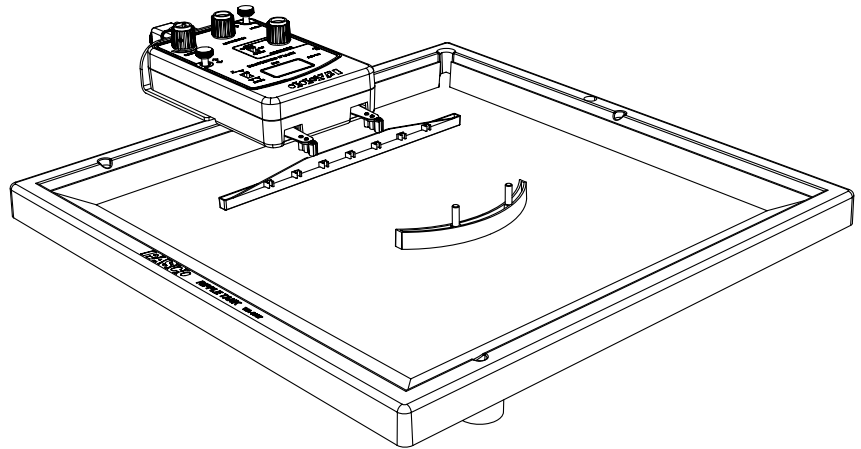

Figure 1.3: Position of Curved Barrier

Data Analysis

1. Use a drawing compass to complete the traced circular shape of the curved barrier. Mark the center of the circle and measure the radius.

Question

1. What is the shape of the wave fronts that reflect from the curved barrier when you dropped the droplet of water into the ripple tank?
2. How is the radius of the circle related to the distance between the curved barrier and the point where the reflected plane waves from the plane wave dipper appeared to converge?

Extension

Turn the curved barrier around by 180 degrees so that it 'curves away' from the plane wave barrier as shown in Figure 1.4. Repeat the procedure as before, but trace the shape of the reflected waves as well as the outline of the curved barrier.

After sketching the reflected waves, draw at least three rays perpendicular to the reflected waves. Extend the rays until they intersect and mark the point of intersection. Measure the distance from the outline of the curved barrier to the point of intersection, and compare this distance to the radius of the traced circular shape of the curved barrier.

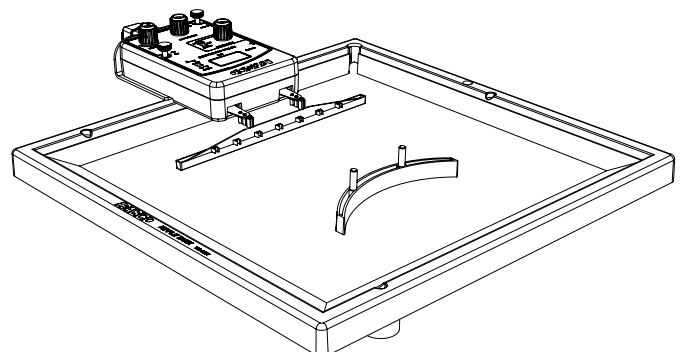

Figure 1.4: Reverse the Curved Barrier

Experiment 2: Refraction

Equipment from Ripple Tank System

| | |
|-----------------------|-----------------------------------|
| Ripple Tank | Ripple Generator and Light Source |
| Trapezoidal Refractor | Plane Wave Dipper |
| Concave Refractor | Ruler |
| Convex Refractor | |

Other Equipment and Materials

| | |
|---------------------------|------------------------------|
| Large Rod Stand (ME-8735) | Paper (about 40 cm by 40 cm) |
| 90-cm Rod (ME-8738) | |

Purpose

The purpose of this activity is to show how waves change direction as they pass from one region to another where the wave speed is different.

Theory

As a wave travels from one medium to another where the wave speed is different, the wave bends to a new direction. If the wave slows down, the wave will bend toward the normal of the interface between one medium and the other as shown in Figure 2.1. This bending is called refraction.

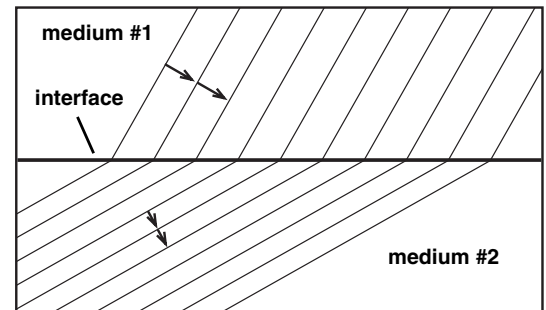
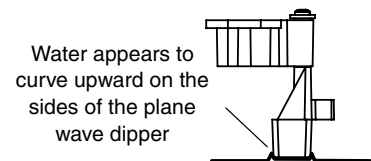

Figure 2.1: Refraction

Setup

1. Mount the light source onto its rod at the back edge of the ripple tank.
2. Pour a small amount of water into the tank and adjust the feet on the legs of the tank to level the tank.
3. Place the trapezoidal refractor in the middle of the tank and add about 700 mL of water, or enough water so that the water level is at the top edge of the refractor.
4. Use a rod and base to support the ripple generator and position the generator over the midpoint of one side of the ripple tank. Plug the light source into the ripple generator and connect the ripple generator to its power adapter.
5. Connect the plane wave dipper to the ripple arms. Adjust the ripple generator until the bottom of the plane wave dipper is barely in contact with the surface of the water.
6. Place a sheet of paper directly under the ripple tank so you will be able to sketch the images of the waves that are projected onto the sheet by the light source.

Tip: Make sure that the plane wave dipper is in contact with the water evenly over its length.



Part 1: Refraction Using a Straight Barrier

Procedure

1. Arrange the trapezoidal refractor in the water in the middle of the tank so the rectangular end of the refractor is parallel to the plane wave dipper and about 5 cm from the dipper (see Figure 2.2).
2. Add just enough water to the tank so that the refractor is evenly covered by less than 1 mm of water.
3. Turn on the ripple generator and the light source. Set the light source to 'STROBE'. Set the ripple generator frequency to 15 Hz or less. Set the amplitude to slightly less than half of maximum and adjust it as necessary to make a clear pattern of plane waves.
4. On the paper below the tank, trace the outline of the trapezoidal refractor.
5. Place the ruler parallel to the plane waves that are incoming to the refractor. Sketch lines to show the incoming wave fronts.
6. On the outline of the refractor, trace the shapes of the refracted waves to show the bending of the refracted waves as they travel over the refractor.
7. After sketching the waves, *reverse* the trapezoidal refractor so that the triangular end of the refractor points toward the plane wave dipper and repeat the procedure.
8. Turn off the ripple generator and light source.

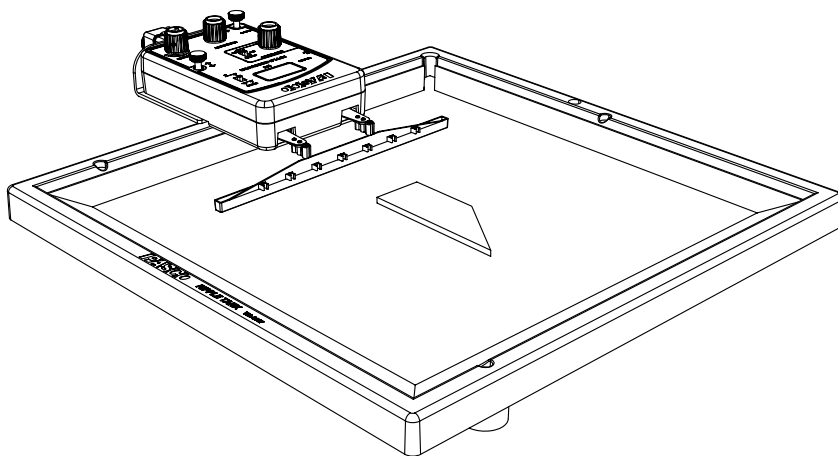

Figure 2.2: Position of Trapezoidal Refractor

Tip: Adjust the frequency as needed to make a clear wave pattern as the waves move over the refractor. The lower the frequency, the more pronounced the refraction.

Data Analysis

1. Draw a line that is perpendicular to the incoming wave front and extend the line to the outline of the trapezoidal refractor. This represents the incoming ray, so draw an arrow on it pointing to the refractor.
2. At the point where the line representing the incoming ray meets the outline of the refractor, draw a new line that is perpendicular to the wave fronts of the refracted waves as they pass over the trapezoidal refractor.

Questions

1. What happens to the direction of the wave fronts as they move over the trapezoidal refractor?
2. As the plane wave from the deep water moves through the shallower water over the refractor, does the plane wave speed up or slow down?

Part 2: Refraction Using Curved Refractors

Procedure

1. Replace the trapezoidal refractor with the convex refractor, placing it in the middle of the tank with the straight side parallel to the plane wave dipper and about 5 cm from the dipper as shown in Figure 2.3.
2. Turn on the ripple generator and light source. Trace the position of the convex refractor on the paper below the ripple tank.
3. Trace the pattern of plane waves as they move from the plane wave dipper over the convex refractor.
4. Use the ruler to measure the focal length of the convex 'lens'. This is the distance from the center of the lens to the point where the refracted plane waves appear to converge (come to a focus).
5. Replace the convex refractor with the concave refractor and trace the new pattern of the plane waves as they move from the dipper over the refractor.

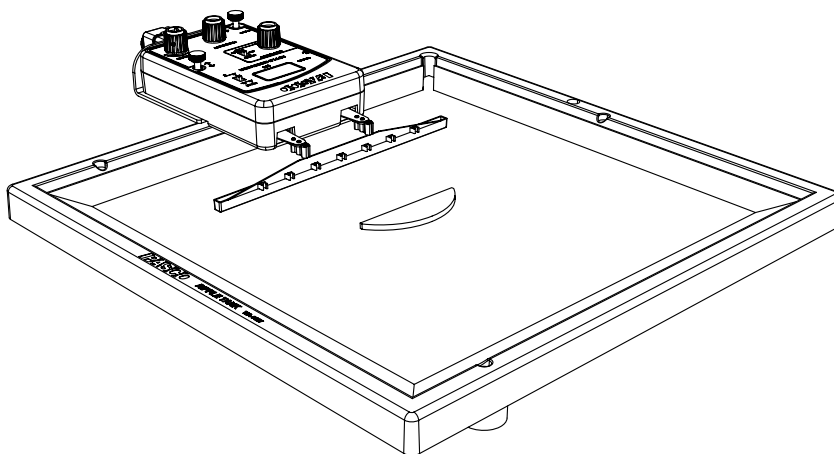

Figure 2.3: Position of Convex Refractor

Data Analysis

1. Use the ruler to sketch three rays that represent the direction of motion for three sections of the plane waves from the dipper as they pass over the convex refractor. Draw one ray for the wave fronts that move over the upper third of the convex refractor; draw a second ray for the wave fronts that move over the center third of the refractor, and draw a third ray for the wave fronts that move over the lower third of the refractor.
2. Repeat the sketching of rays for the wave pattern of the waves moving over the concave refractor. Draw one ray for the wave fronts that move over the upper third of the concave refractor; draw a second ray for the wave fronts that move over the center third of the refractor, and draw a third ray for the wave fronts that move over the lower third of the refractor.

Questions

1. What happens to the direction of the rays for the wave fronts of the plane waves as they move over the concave refractor?
2. Do the refracted waves from the concave refractor appear to converge or diverge?

Experiment 3: Diffraction

Equipment from Ripple Tank System

| | |
|------------------|-----------------------------------|
| Ripple Tank | Ripple Generator and Light Source |
| Long Barrier (2) | Plane Wave Dipper |
| Mini Barrier | Ruler |

Other Equipment and Materials

| | |
|---------------------------|------------------------------|
| Large Rod Stand (ME-8735) | Paper (about 40 cm by 40 cm) |
| 90-cm Rod (ME-8738) | |

Purpose

The purpose of this activity is to determine how the diffraction pattern of plane waves changes as the slit width (gap between barriers) changes and the wavelength changes.

Theory

As a plane wave front passes through a gap or slit in a barrier, each point on the wave front that moves through the slit generates a new circular wave front. If the gap or slit is large relative to the wavelength, the circular wave fronts combine to form a new plane wave front. If the gap or slit is small relative to the wavelength, the part of the wave front that moves through the slit is less like a plane wave and more like a circular wave. The spreading of a circular wave created as a wave front moves through a slit as shown in Figure 3.1 is called diffraction.

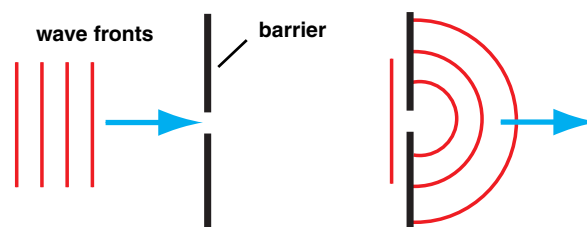

Figure 3.1: Diffraction

Setup

1. Mount the light source onto its rod at the back edge of the ripple tank.
2. Pour a small amount of water into the tank and adjust the feet on the legs of the tank to level the tank.
3. Place the long straight barriers in the middle of the tank and add about 800 mL of water to the tank (or enough water so that the water level is about halfway up the long straight barrier.)
4. Use a rod and base to support the ripple generator and position the generator over the midpoint of one side of the ripple tank. Plug the light source into the ripple generator and connect the ripple generator to its power adapter.
5. Connect the plane wave dipper to the ripple arms. Adjust the ripple generator until the bottom of the plane wave dipper is barely in contact with the surface of the water.
6. Set the light source to 'STROBE'. Set the ripple generator to 20 Hz and the amplitude to slightly less than half of maximum.
7. Place a sheet of paper directly under the ripple tank so you will be able to sketch the images of the waves that are projected onto the sheet by the light source.

Tip: Make sure that the plane wave dipper is in contact with the water evenly over its length.

Water appears to curve upward on the sides of the plane wave dipper



Procedure: Straight Barriers

1. Arrange the two long barriers in the water so that they are about 3 cm apart and parallel to the plane wave dipper as shown in Figure 3.2. Set them so that they are about 5 cm from the plane wave dipper.
2. Turn on the ripple generator and the light source. Adjust the amplitude as needed to make a clear wave pattern.
3. On the paper below the tank, trace the outline of the two long barriers.
4. Sketch the wave fronts and the rays that represent the waves as they spread out when they pass through the slit between the barriers.
5. Change the slit width to about 1.5 cm by sliding the two barriers closer together.
6. Sketch the new rays that represent the waves as they spread out when they pass through the slit.
7. Keep the same slit width of 1.5 cm, but increase the frequency of the ripple generator and observe what happens to the wavelength and to the angle of spreading.

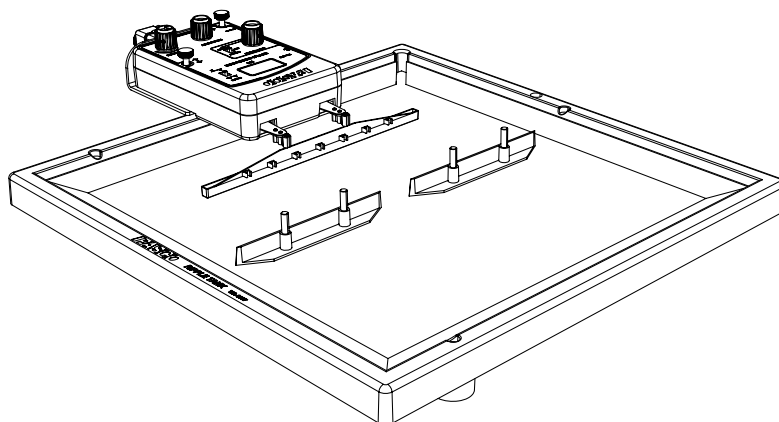

Figure 3.2: Position of Long Barriers

Questions

1. Is the angle of diffraction (spreading) for the narrower slit (1.5 cm) more or less than the angle for the wider slit (3.0 cm)?
2. How does the increase in frequency affect the wavelength?
3. How does the increase in frequency affect the angle of spreading (amount of diffraction) as the wave fronts move through the slit?

Procedure: Solid Object

1. Return the frequency of the ripple generator to 20 Hz.
2. Place the mini barrier in the gap between the long barriers and then remove the long barriers.
3. Sketch the resulting wave pattern as the wave fronts go around the mini barrier.
4. Increase the frequency of the ripple generator as before and observe what happens to the wave pattern.

Questions

1. What happens to the plane wave fronts as they pass by the mini barrier?
2. How does the increase in frequency affect what happens to the plane wave fronts as they pass by the mini barrier?

Experiment 4: Interference

Equipment from Ripple Tank System

| | |
|------------------|-----------------------------------|
| Ripple Tank | Ripple Generator and Light Source |
| Long Barrier (2) | Plane Wave Dipper |
| Short Barrier | Standard Dipper (2) |
| Mini Barrier | |

Other Equipment and Materials

| | |
|---------------------------|------------------------------|
| Large Rod Stand (ME-8735) | Paper (about 40 cm by 40 cm) |
| 90-cm Rod (ME-8738) | |

Purpose

The purpose of this activity is to determine how the interference pattern formed by two slits or two point sources changes as the slit width changes and the wavelength changes.

Theory

When a wave front passes through two slits, the wave front acts like two point sources. The circular wave patterns that spread from the slits interfere constructively and destructively. The positions of maximum intensity (constructive interference) are given by the following formula:

$$d \sin \theta = m \lambda$$

In the formula, ' d ' is the slit separation, ' θ ' is the angle between positions of maximum intensity (the 'maxima'), ' λ ' is the wavelength, and ' m ' is the order where ' m ' = 0, 1, 2, etc. See Figure 4.1.

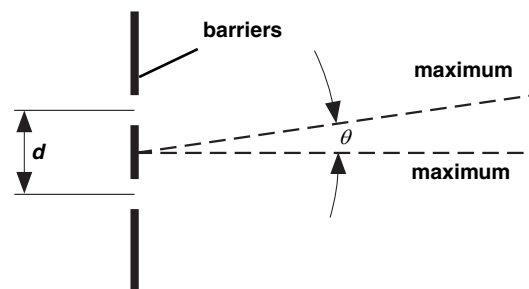
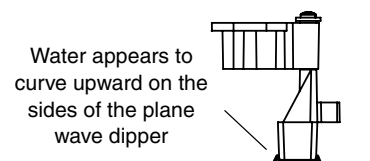

Figure 4.1: Diffraction

Setup: Straight Barriers

1. Mount the light source onto its rod at the back edge of the ripple tank.
2. Pour a small amount of water into the tank and adjust the feet on the legs of the tank to level the tank.
3. Place the long straight barriers in the middle of the tank and add about 800 mL of water to the tank (or enough water so that the water level is about halfway up the long straight barrier.)
4. Use a rod and base to support the ripple generator and position the generator over the midpoint of one side of the ripple tank. Plug the light source into the ripple generator and connect the ripple generator to its power adapter.
5. Connect the plane wave dipper to the ripple arms. Adjust the ripple generator until the bottom of the plane wave dipper is barely in contact with the surface of the water.
6. Place a sheet of paper directly under the ripple tank so you will be able to sketch the images of the waves that are projected onto the sheet by the light source.

Tip: Make sure that the plane wave dipper is in contact with the water evenly over its length.



Water appears to curve upward on the sides of the plane wave dipper

Procedure: Straight Barriers

1. Place the short barrier between the two long barriers in the water to form two openings that are 2 cm long. Put the barriers parallel to the plane wave dipper as shown in Figure 4.2. Set the barriers about 5 cm from the plane wave dipper
2. Turn on the ripple generator and the light source. Set the light source to 'STROBE'. Set the frequency to 20 Hz and the amplitude to slightly less than half of maximum.
3. On the paper below the tank, trace the outline of the barriers.
4. Sketch the wave fronts and the rays that represent the waves as they spread out and interfere after they pass through the slits between the barriers.
5. Find and label the regions where the waves from the two slits tend to cancel each other and find and label the regions where the waves add together to make waves with higher peaks.
6. Decrease the slit separation. *Replace the short barrier with the mini barrier but keep the slit width at 2 cm.*
7. Vary the frequency. Keep the slip separation and slit width the same, but *increase* the frequency to decrease the wavelength.

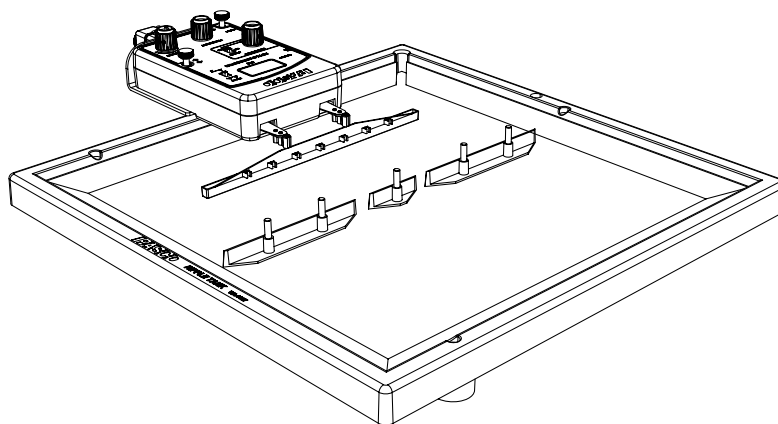

Figure 4.2: Position of Barriers

Tip: Adjust the amplitude to make a clear pattern of plane waves.

Questions

1. When the slit separation is decreased, does the spread angle of the waves increase or decrease?
2. When the frequency increases and the wavelength decreases, does the spread angle of the waves increase or decrease?

Setup: Two Point Sources

1. Temporarily turn off the ripple generator.
2. Remove the straight barriers from the tank and replace the plane wave dipper in the ripple arms with two standard dippers (see Figure 4.3). Adjust the ripple generator so that the two standard dippers barely touch the surface of the water.

Procedure: Two Point Sources

1. Turn on the generator and return the frequency to 20 Hz. Adjust the amplitude as needed to make a clear pattern.
2. Sketch the wave pattern formed as the wave fronts from the two point sources interfere with each other.

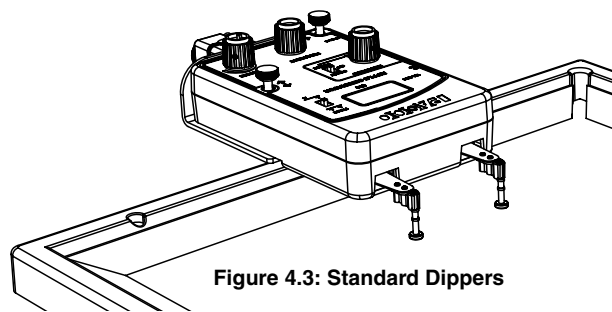

Figure 4.3: Standard Dippers

Question

1. How does the pattern of interference from two point sources compare to the pattern of interference from the two slits?

Extensions

Three Point Sources Raise the ripple generator, remove the two standard dippers, and attach the plane wave dipper to the ripple arms. Put three standard dippers into the clips on the plane wave dipper so that the three dippers are evenly spaced. Adjust the ripple generator so that the three standard dippers barely touch the surface of the water.

Set the ripple generator frequency to 20 Hz, and repeat the procedure as you did for two point sources. Adjust the amplitude as needed to make a clear pattern.

Sketch the wave pattern formed as the wave fronts from the three point sources interfere with each other.

Five Point Sources Put two more standard dippers into the clips on the plane wave dipper so that all five dippers are evenly spaced (see Figure 4.4). Repeat the procedure as for three point sources.

Sketch the wave pattern formed as the wave fronts from the five point sources interfere with each other.

Actuators Raise the ripple generator and remove the plane wave dipper. Attach a dipper adapter to each of the two small actuators, and put the dipper adapters into the clips on the ripple arms (see Figure 4.5). Adjust the ripple generator so that the two small actuators barely touch the surface of the water. Repeat the procedure as for the two point sources. Adjust the amplitude as needed to make a clear pattern.

Sketch the wave pattern formed as the wave fronts from the two small actuators interfere with each other.

Replace the two small actuators with the two large actuators and repeat the procedure.

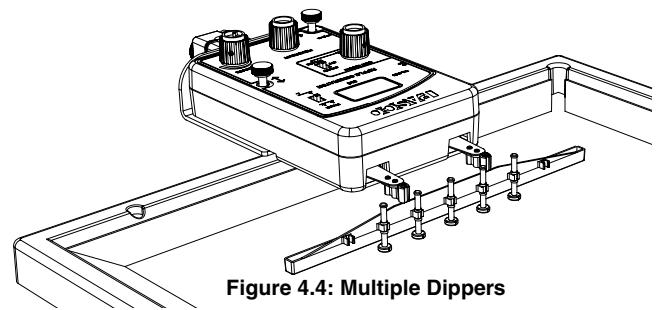

Figure 4.4: Multiple Dippers

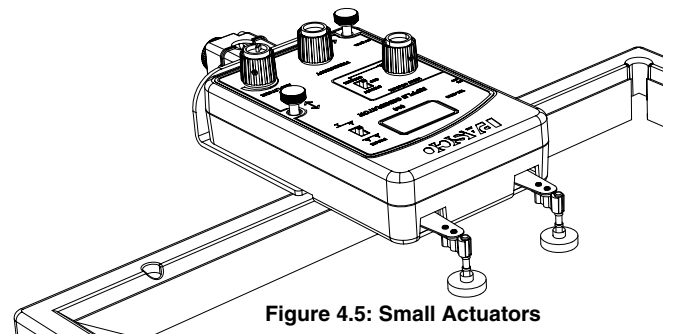

Figure 4.5: Small Actuators

Notes

Experiment 5: Image Formed by a Plane Mirror

Equipment from Ripple Tank System

| | |
|--------------|-----------------------------------|
| Ripple Tank | Ripple Generator and Light Source |
| Long Barrier | Standard Dipper |
| Ruler | |

Other Equipment and Materials

| | |
|---------------------------|------------------------------|
| Large Rod Stand (ME-8735) | Paper (about 40 cm by 40 cm) |
| 90-cm Rod (ME-8738) | |

Purpose

The purpose of this activity is to show how the position of the image formed by a plane mirror relates to the position of the object.

Theory

When wave fronts reflect from a plane mirror's surface, the angle of incidence of the ray equals the angle of reflection of the ray. The image formed by a plane mirror appears to be a certain distance behind the mirror. This distance is called the 'image distance'. The distance of the object in front of the mirror is called the 'object distance'. The relationship of the angles of incident rays and reflected rays can be used to find the relationship of the 'image distance' to the object distance. See Figure 5.1.

Setup

1. Mount the light source onto its rod at the back edge of the ripple tank.
2. Pour a small amount of water into the tank and adjust the feet on the legs of the tank to level the tank.
3. Place the long straight barrier in the middle of the tank and add about 800 mL of water to the tank (or enough water so that the water level is about halfway up the long straight barrier.)
4. Use a rod and base to support the ripple generator and position the generator over the midpoint of one side of the ripple tank. Adjust the generator so that one ripple arm is in line with the center of the tank.
5. Plug the light source into the ripple generator and connect the ripple generator to its power adapter.
6. Connect a single standard dipper to one of the ripple arms. Adjust the ripple generator until the bottom of the standard dipper is barely in contact with the surface of the water.
7. Place a sheet of paper directly under the ripple tank so you will be able to sketch the images of the waves that are projected onto the sheet by the light source.

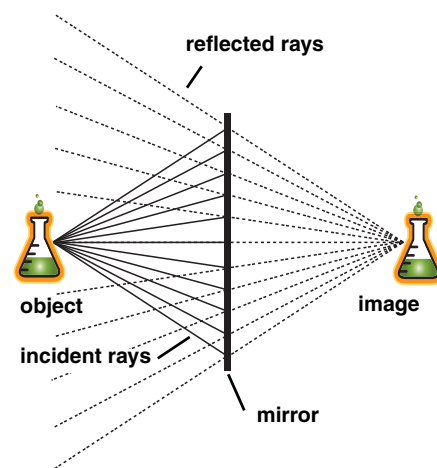

Figure 5.1: Plane Mirror

8. Arrange the long barrier near the middle of the tank so that the midpoint of the barrier is aligned with the ripple arm that holds the standard dipper. Adjust the barrier so it is parallel to the front of the ripple generator as in Figure 5.2.

Procedure

1. Turn on the ripple generator and the light source. Set the light source to 'STROBE'. Set the frequency to 20 Hz and the amplitude to slightly less than half of maximum. Adjust the amplitude to make a clear wave pattern.
2. On the paper below the tank, trace the outline of the standard dipper and the long barrier.
3. Sketch the wave fronts and the rays that represent the waves as they move from the dipper and reflect from the long barrier.

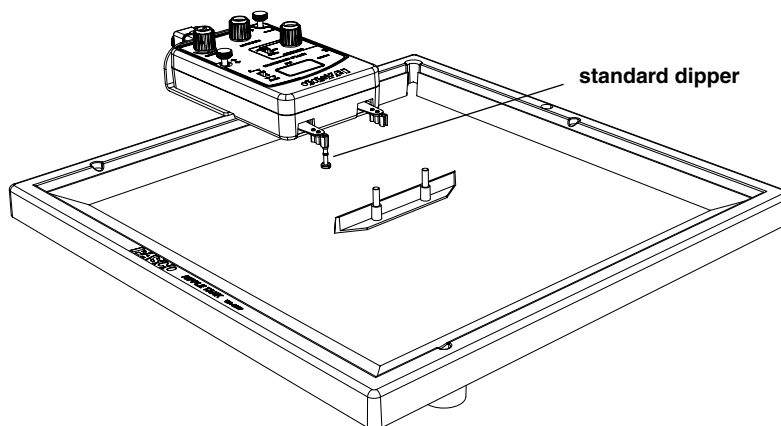

Figure 5.2: Position of Barrier

4. Measure and record the distance from the outline of the standard dipper to the outline of the long barrier.
5. Place the ruler on the paper with one end of the ruler at any point on the line that indicates the side of the long barrier that faces the standard dipper. Orient the ruler so that it crosses the reflected circular wave fronts at a right angle. Draw a line along the ruler to indicate the ray for the reflected wave fronts.
6. Move the end of the ruler to a new point on the outline of the long barrier. Orient it again so it crosses the reflected circular wave fronts at a right angle. Draw a new line along the ruler to indicate the ray for the reflected wave fronts from this point.
7. Turn off the ripple generator.
8. Extend the two ruler lines until they cross. The point where they cross is the center of the reflected circular wave fronts. This center represents the position of the image.
9. Measure and record the perpendicular distance from the front side of the barrier to the position of the image.

Questions

1. Where is the position of the image located relative to the long barrier and the standard dipper?
2. How does the distance to the position of the image compare to the distance from the standard dipper to the long barrier?

Experiment 6: Wave Speed

Equipment from Ripple Tank System

| | |
|-------------------|-----------------------------------|
| Ripple Tank | Ripple Generator and Light Source |
| Plane Wave Dipper | Ruler |

Other Equipment and Materials

| | |
|---------------------------|------------------------------|
| Large Rod Stand (ME-8735) | Paper (about 40 cm by 40 cm) |
| 90-cm Rod (ME-8738) | |

Purpose

The purpose of this activity is to demonstrate the relationship of wave speed to frequency ($v = f\lambda$ where v is the speed of propagation of the wave, f is the frequency, and λ is the wavelength) and wave speed to water depth.

Theory

For transverse waves, the wavelength is the distance from one point on a wave to an identical point on the next wave, such as the distance from one crest to the next crest. Frequency is the number of waves per unit of time. Period, the amount of time for one wave, is the reciprocal of frequency. Since average speed is distance divided by time, wave speed is wavelength divided by period, or wavelength multiplied by frequency (the reciprocal of the period). See Figure 6.1.

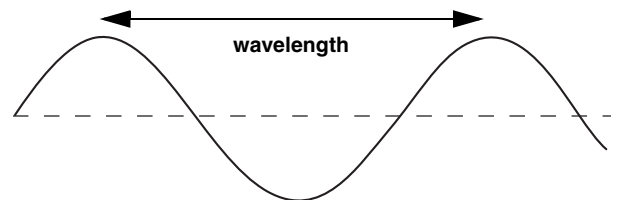

Figure 6.1: Wavelength

Setup: Wave Speed

1. Mount the light source onto its rod at the back edge of the ripple tank.
2. Fill the ripple tank with a small amount of water and adjust the feet on the legs to level the tank. Then add between 600 and 800 mL of water.
3. Use a rod and base to support the ripple generator and position the generator over the midpoint of one side of the ripple tank.
4. Plug the light source into the ripple generator and connect the ripple generator to its power adapter.
5. Connect the plane wave dipper to the ripple arms. Adjust the ripple generator until the bottom of the plane wave dipper is barely in contact with the surface of the water. See Figure 6.2.
6. Place a sheet of paper directly under the ripple tank so you will be able to measure the distances between wave fronts.

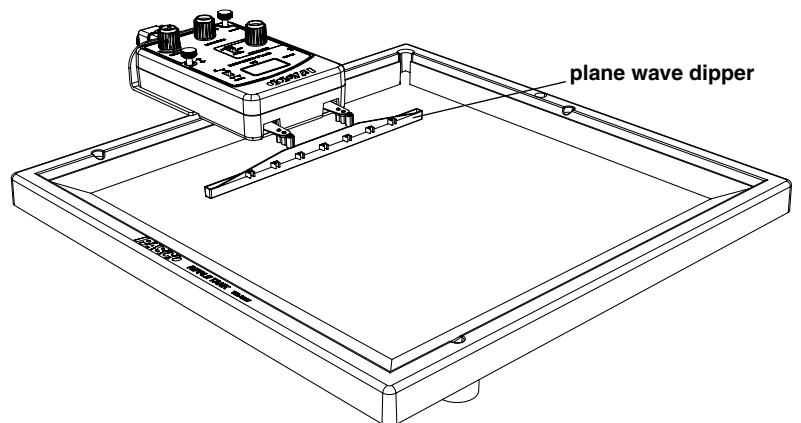

Figure 6.2: Plane Wave Dipper

Procedure: Wave Speed and Frequency

1. Turn on the ripple generator and the light source. Set the light source to 'STROBE'. Set the frequency to 5 Hz and the amplitude slightly less than half of maximum. Adjust the amplitude if needed to make a clear wave pattern.
2. The waves fronts appear as light and dark stripes that are formed as light travels through wave crests and troughs. Measure and record the distance of five wave-lengths.
3. Choose a new frequency and repeat the measurement of the distance for five wavelengths. Do this for five different frequencies.
4. Calculate the wavelength that corresponds to each different frequency.
5. Based on the wavelength and frequency, calculate the wave speeds.
6. Calculate the average wave speed.

Table 6.1:

| Frequency (Hz) | 5 Hz | | | | |
|--------------------|------|--|--|--|--|
| Five λ (m) | | | | | |
| λ (m) | | | | | |
| v (m/s) | | | | | |

Question

1. Is the wave speed roughly constant for the frequencies you chose?

Procedure: Wave Speed and Water Depth

1. Set the ripple generator frequency to 5 Hz. Measure and record the distance of five wavelengths as in the previous procedure.
2. Drain or add water so the depth is 7 mm. Adjust the ripple generator so the plane wave dipper is barely in contact with the surface of the water. Measure and record the distance of five wavelengths as before.
3. Repeat the procedure for depths of 5 mm and 2 mm.
4. Calculate the wavelength and wave speed for each water depth.

Table 6.2:

| Depth of Water (mm) | Five λ (m) | λ (m) | Wave Speed (m/s) |
|---------------------|--------------------|---------------|------------------|
| 10 | | | |
| 7 | | | |
| 5 | | | |
| 2 | | | |

Question

1. How does the speed of the wave depend on the depth of the water?

Doppler Effect Demonstration

The Doppler effect occurs when a wave source moves relative to an observer in such a way that the distance between the wave source and the observer changes. If the distance between the wave source and the observer decreases, the wavelength becomes shorter. If the distance between the wave source and the observer increases, the wavelength becomes longer.

The Doppler effect can be demonstrated using the Ripple Tank System. Arrange the ripple generator and ripple tank as for the previous experiments. Mount the light source on its rod and connect the light source to the generator. Put a standard dipper into one of the ripple arms of the ripple generator. Turn on the generator. Start with the ripple generator's default frequency of 20Hz. Set the amplitude to about half-maximum and the light source to 'STROBE'. See the figure.

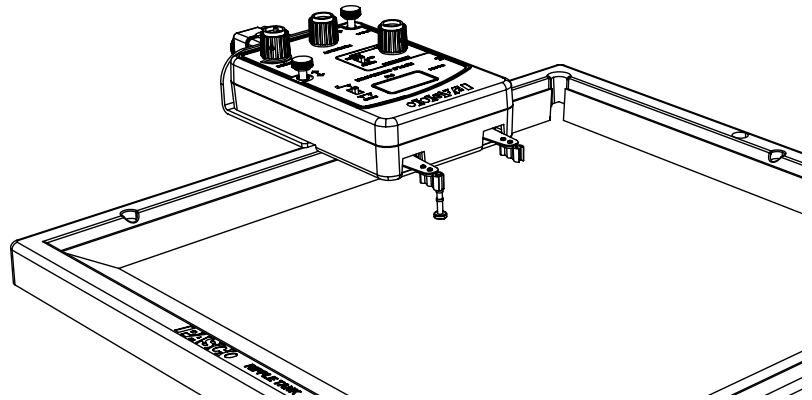

Figure: Doppler Demonstration

By moving the ripple generator at a constant speed, the Doppler phenomenon can be observed as shown in the illustration. It will require some experimenting to determine the right speed to use for a given frequency.

One way to move the ripple generator is to simply pivot the generator on its support rod. To do this, grip the rod with one hand just below the generator's rod clamp. Slightly loosen the rod clamp and use your thumb to support the clamp so that the generator stays at the same vertical position on the rod. Use the other hand to rotate the generator one way and then the other. Wavelengths in front of the moving dipper will decrease, and wavelengths behind the moving dipper will increase.



Direction of motion →

Sample Results

These illustrations show sample results for the refraction experiments.

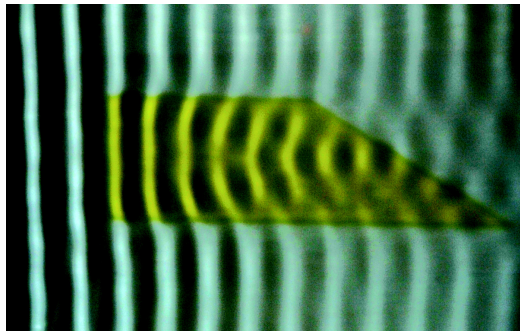

Refraction with Trapezoid

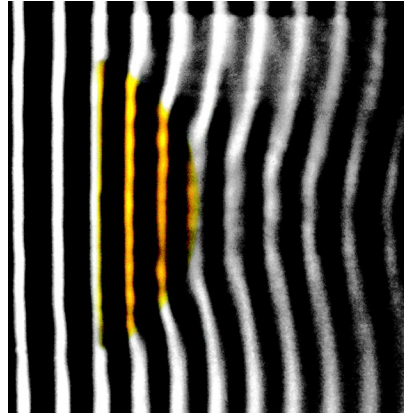

Refraction with Convex Refractor

This illustration shows a sample result for the two-slit diffraction experiment,

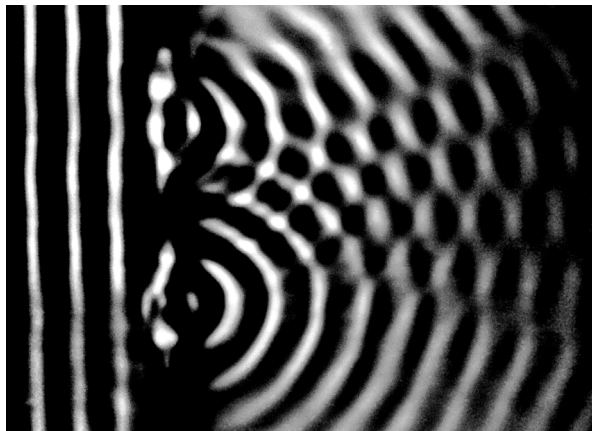

This illustration shows a sample result for the two-point source interference experiment.

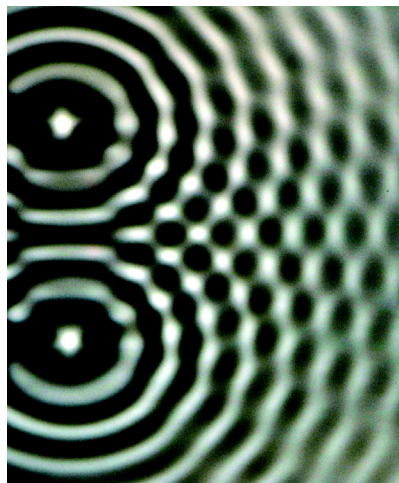

Technical Support

For assistance with any PASCO product, contact PASCO at:

Address: PASCO scientific
10101 Foothills Blvd.
Roseville, CA 95747-7100

Phone: 916-786-3800 (worldwide)
800-772-8700 (U.S.)

Fax: (916) 786-7565

Web: www.pasco.com

Email: support@pasco.com

Limited Warranty

For a description of the product warranty, see the PASCO catalog.

Copyright

The PASCO scientific 012-09956A *Ripple Tank System Instruction Manual and Experiment Guide* is copyrighted with all rights reserved. Permission is granted to non-profit educational institutions for reproduction of any part of this manual, providing the reproductions are used only in their laboratories and classrooms, and are not sold for profit. Reproduction under any other circumstances, without the written consent of PASCO scientific, is prohibited.

Trademarks

PASCO and PASCO scientific are trademarks or registered trademarks of PASCO scientific, in the United States and/or in other countries. All other brands, products, or service names are or may be trademarks or service marks of, and are used to identify, products or services of, their respective owners. For more information visit www.pasco.com/legal.

Authors: Ann Hanks
Jon Hanks
Dave Griffith