

## Wireless 3-Axis Acceleration/Altimeter

PS-3223

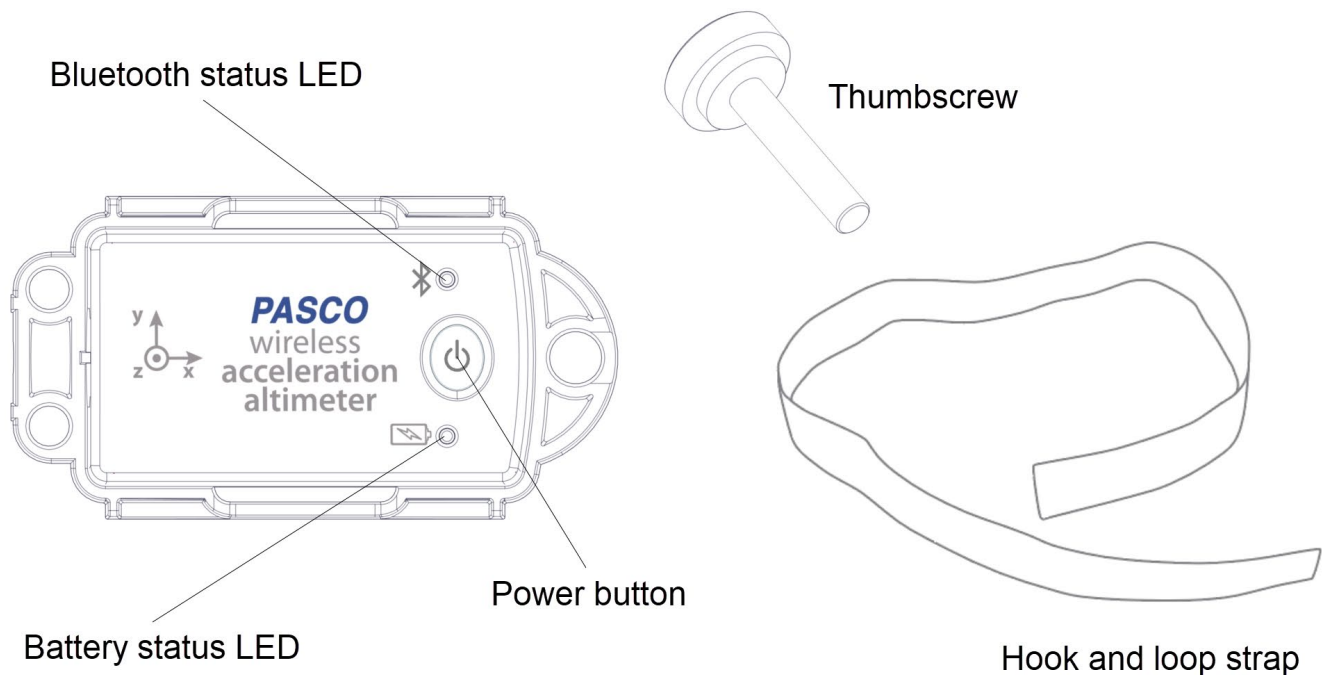

### Included Equipment

Wireless Acceleration/Altimeter sensor  
Thumbscrew, M5 X 25mm  
Hook and loop strap

### Introduction

The PS-3223 Wireless 3-Axis Acceleration/Altimeter sensor measures acceleration in three axes, angular velocity in three axes, and altitude. The sensor can be mounted to any PASCO cart using the included thumbscrew. The included hook and loop strap can be used to mount the sensor to a variety of objects. For additional mounting options, the sensor casing includes a threaded hole that accepts 6-32 screws, such as the PASCO Truss Set Screws.

### Collecting data

#### SPARKvue

1. Press and hold the power button until the Bluetooth status LED starts flashing red.
2. Open SPARKvue and select Sensor Data.
3. Under Connected Devices, select the sensor that matches your device ID.
4. Select the measurements you wish to display.
5. Under Templates, select Graph.
6. Select Start to begin data collection.

## PASCO Capstone

1. Press and hold the power button until the Bluetooth status LED starts flashing red.
2. Open Capstone and click Hardware Setup.
3. Select the sensor that matches your device ID.
4. In the Displays palette, double-click Graph.
5. On the vertical axis of the graph, click Select Measurement, then select the measurement you wish to display.
6. Click Record to begin data collection.

## Data collection tips

### Acceleration

Acceleration is measured using an electronic three-axis accelerometer. Due to the way an accelerometer functions, the acceleration measurement will be offset by  $9.8 \text{ m/s}^2$  in the direction normal to the surface of Earth. For example, if the x-axis of the sensor is normal to Earth's surface, this axis will measure  $9.8 \text{ m/s}^2$  when at rest. If the sensor is rotated so that the y-axis is normal to Earth's surface, the y-axis will now measure  $9.8 \text{ m/s}^2$  (Figure 1).

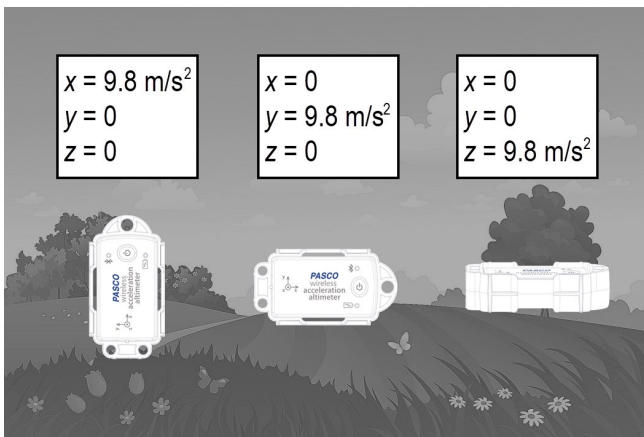

Figure 1. Acceleration will be offset by  $9.8 \text{ m/s}^2$  in the direction normal to the Earth's surface.

It is recommended to zero the acceleration sensor when collecting data in one-dimension (such as the acceleration of a cart on an inclined plane). However, the sensor should *not* be zeroed when collecting data in all three axes simultaneously. This will result in the sensor reporting invalid acceleration measurements whenever the sensor changes direction.

The default measurement range is  $\pm 16 \text{ g}$ . For high-g acceleration measurements, the range can be changed to  $\pm 100 \text{ g}$ ,  $\pm 200 \text{ g}$ , or  $\pm 400 \text{ g}$ . Increasing the measurement range will decrease the accuracy and resolution of the sensor. Select the smallest range required when recording data to provide the most precise and accurate acceleration data.

### Altitude

Altitude is measured by detecting changes in barometric pressure. Since barometric pressure can vary due to weather conditions, the sensor is best used to measure changes in altitude instead of absolute altitude. The sensor is most useful when measuring significant changes in altitude such as riding a roller coaster or launched as a projectile.

## Mounting options

### PASCO carts

Align one of the holes in the sensor casing with a threaded hole in the accessory tray of the cart. Fasten with the included thumbscrew. Be sure to pay attention to the direction of the x-axis of the sensor when mounting.

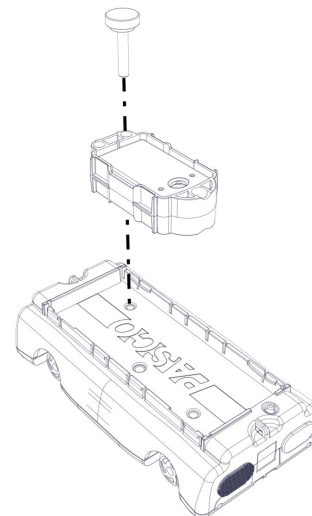

Figure 2. Mount the sensor to a PASCO cart using the included thumb screw.

### Hook and loop strap

Insert each end of the strap through the slots between the sensor and the casing. Use the strap to mount the sensor to an object such as a human arm. Two indentations in the casing accommodate for mounting to a rod (such as the rod included with the ME-8969 Pendulum Accessory or ME-3420 Rotational Inertia Accessory).

## Rotating Platform

The sensor can be mounted to the track of the ME-8951 Rotating Platform. Secure the sensor to the track using the thumbscrew and square nut included with the 300 g square mass. Be sure to pay attention to the direction of the x and y axes of the sensor when mounting.

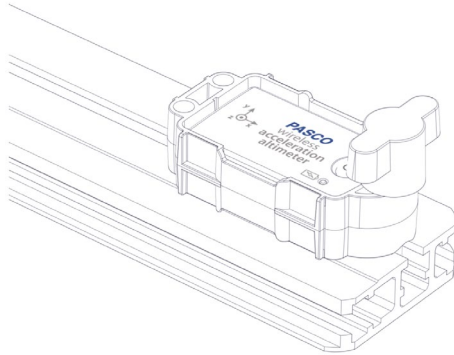

Figure 3. Sensor mounted to the ME-8951 Rotating Platform.

## Truss Set Member

The threaded hole on the sensor casing can be used to attach the sensor to a PASCO Truss Set Member. Other objects (such as masses) can be attached to the sensor using 6-32 screws.

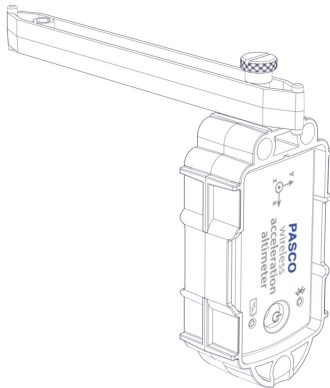

Figure 4. Sensor mounted to a PASCO Truss Set Member.

## String or rubber band

Tie a string to the center mounting hole in the sensor casing. Use the string to swing the sensor in a circle to measure centripetal acceleration.

Tie a rubber band to the hole. Use the rubber band to launch sensor to explore projectile motion.

## Battery Replacement

1. Insert a coin into the battery compartment door slot then turn the door counterclockwise until the indicator aligns with the second mark.
2. Remove the battery compartment door, O-ring gasket, and battery.
3. Insert a new CR2032 battery in the compartment with the positive (+) side facing up.
4. Replace the door and O-ring gasket, aligning the indicator with the second mark.
5. Turn the battery compartment door clockwise until the indicator aligns with the first mark.

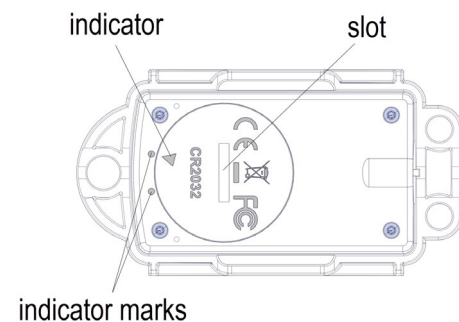

Figure 5. Battery compartment door.

## LED Status

Bluetooth LED	Status
Red blink	Ready to be connected to software
Green blink	Connected to software
Yellow blink	Remotely logging data

Battery LED	Status
Red blink	Battery needs to be replaced soon
Green solid	Battery is fully charged
Yellow solid	Battery is charging

## Specifications

### Low-g Accelerometer

Range	$\pm 16$ g
Accuracy	$\pm 0.04$ g
Resolution	0.001 g
Max sample rate	1 kHz
Max sample rate (burst)	5 kHz

### Low-g Accelerometer

Range	$\pm 100$ g, $\pm 200$ g, $\pm 400$ g
Accuracy	$\pm 1$ g (@ $\pm 100$ g)
Resolution	0.1 g (@ $\pm 100$ g)
Max sample rate	1 kHz

### Gyroscope

Range	$\pm 34.9$ rad/s
Accuracy	$\pm 0.017$ rad/s
Max sample rate	1 kHz
Max sample rate (burst)	5 kHz

### Altimeter

Range	-1869.65 – 9481.98 m
Accuracy	$\pm 0.5$ m
Resolution	5 cm
Max sample rate	1 kHz

## Technical Support

For assistance with PASCO products, contact PASCO at:

Address: PASCO scientific  
10101 Foothills Blvd.  
Roseville, CA 95747-7100

Phone: 916-462-8384

Web: [www.pasco.com](http://www.pasco.com)

Email: [support@pasco.com](mailto:support@pasco.com)

## Product End of Life Disposal Instructions

This electronic product is subject to disposal and recycling regulations that vary by country and region. It is your responsibility to recycle your electronic equipment per your local environmental laws and regulations to ensure that it will be recycled in a manner that protects human health and the environment. To find out where you can drop off your waste equipment for recycling, please contact your local waste recycle/disposal service, or the place where you purchased the product.

The European Union WEEE (Waste Electronic and Electrical Equipment) symbol (to the right) and on the product or its packaging indicates that this product must not be disposed of in a standard waste container.



## Warranty, Copyright, and Trademarks

**Limited Warranty** For a description of the product warranty, see the PASCO catalog.

**Copyright** This document is copyrighted with all rights reserved. Permission is granted to non-profit educational institutions for reproduction of any part of this manual, providing the reproductions are used only in their laboratories and classrooms, and are not sold for profit. Reproduction under any other circumstances, without the written consent of PASCO scientific, is prohibited.

**Trademarks** PASCO and PASCO scientific are trademarks or registered trademarks of PASCO scientific, in the United States and/or in other countries. All other brands, products, or service names are or may be trademarks or service marks of, and are used to identify, products or services of, their respective owners. For more information visit [www.pasco.com/legal](http://www.pasco.com/legal).